

710 P

Backhoe Loader



JOHN DEERE





710 P-TIER BACKHOE LOADER

READY TO RUN IN THE REAL WORLD

When owners and operators just like you — the people who know what customers need for their operations to succeed — weighed in on our latest backhoe loaders, we heeded the real-world feedback. You asked for one machine that capably completes the work of two. A powerful overachiever with outstanding loader performance, backhoe capability, and multifunction versatility. And packed with productivity-elevating options to match the application. Meet the 710 P-Tier Backhoe Loader, a standout multitasker ready to run — and get more done — in any corner of the working world.

FEATURES

Proven engine technology

Reliable EPA Final Tier 4 (FT4)/EU Stage IV John Deere PowerTech™ Plus engine incorporates series turbochargers for increased power and improved torque over earlier models. Wet-sleeve design with replaceable cylinder liners provides uniform cooling and helps reduce oil breakdown and ring wear.

Elevated experience

Pressure-compensated, load-sensing (PCLS) hydraulics provide excellent multifunctioning, smooth machine control, and up to 15-percent greater craning capacity with Lift Mode, collectively providing a distinctive operator experience and unmatched machine performance. Trenching operation can be conducted at a lower engine rpm, reducing fuel consumption and jobsite noise.

Forward thinking

When enabled on the sealed-switch module, AutoShift automatically shifts the PowerShift™ transmission to the appropriate gear. Simply set the control lever to the highest gear desired, and the transmission will optimally shift based on engine rpm and ground speed. Included in the base machine configuration, AutoShift enhances operator ease of use during extended transport or load-and-carry applications.

Always on the move

Limited-slip mechanical-front-wheel drive (MFWD) delivers sure-footed traction in any ground condition. Engage momentary MFWD “on the fly” with a touch of a button on the loader control.

Smooth control

When set ground speed is reached, ride control automatically turns on, creating a smoother ride for the operator and reducing bucket spillage. When the machine drops below the speed setting, ride control turns off, maximizing loader productivity. Auto ride control is standard equipment on the 710 P-Tier.



UP TO
15% MORE
CRANING CAPACITY
WITH LIFT MODE

Nice and precise

Standard precision mode reduces the speed of hydraulic backhoe functions without sacrificing lift performance, for close work around underground utilities or jobsite obstacles, or when lifting — also useful for less experienced operators.

Save fuel with economy mode

Standard economy mode can be configured separately between loader and backhoe functions. Activate economy mode for backhoe functions while retaining full power for loader functions. This helps maximize fuel usage in lighter-work applications with minimal effect on machine performance.

It all looks good from here

Spacious operator station is loaded with creature comforts including an efficient HVAC system, choice of adjustable mechanical or air-suspension seat, and optional premium radio with Bluetooth® and auxiliary input. Sightlines to the loader bucket corners over the sloped hood are clear.

Take it easy

Enhanced “palm-on-top” loader-control grip is intuitive and easy to use. Redesigned loader-lever linkage reduces resistance and improves its throw and feel, decreasing lever travel by up to 15 percent.

Hit the ground running

Same-side ground-level service points speed daily checks and fills. Other commonsense features such as quick-change filters, extended service intervals, simple-to-read sight gauges, and easy-access grease zerks help increase uptime.



**WORK AROUND OBSTACLES
OR UNDERGROUND UTILITIES
WITH PRECISION MODE**



710 P-TIER BACKHOE LOADER



Precision Construction

From grade management and obstacle detection to product automation features and jobsite intelligence, this suite of construction technology delivers productivity solutions to help you get more done, more efficiently.

John Deere construction equipment comes with in-base connectivity – free from subscriptions or annual renewals. Analyze critical machine data, track utilization, review diagnostic alerts, and more from **the John Deere Operations Center™**. The Operations Center also enables **John Deere Connected Support™**, which uses data from thousands of connected machines to proactively address issues before they arise. Your dealer can also remotely monitor machine health, diagnose problems, and even update machine software without a trip to the jobsite.*

*Availability varies by region and product. Options not available in every country.





While general information, pictures, and descriptions are provided, some illustrations and text may include product options and accessories NOT AVAILABLE in all regions, and in some countries products and accessories may require modifications or additions to ensure compliance with the local regulations of those countries.

Engine		710 P-TIER	
Manufacturer and Model	John Deere PowerTech™ Plus 4045HT084 series turbocharged		
Non-Road Emission Standard	EPA Final Tier 4/EU Stage IV		
Displacement	4.5 L (276 cu. in.)		
Gross Peak Power	112 kW (150 hp) at 2,240 rpm		
Net Peak Power (ISO 9249)	110 kW (148 hp) at 2,240 rpm		
Net Peak Torque (ISO 9249)	570 Nm (420 lb.-ft.) at 1,400 rpm		
Net Torque Rise	20%		
Lubrication	Pressure system with spin-on filter and cooler		
Air Cleaner	Dual-stage dry type with safety element and evacuator valve		
Cooling			
Fan Type	Electronically controlled, variable rate, suction-type cooling fan standard		
Engine Coolant Rating	-40 deg. C (-40 deg. F)		
Engine Oil Cooler	Oil to water		
Powertrain			
Transmission	4-speed, helical-cut gears, full PowerShift™ transmission with hydraulic reverser standard; electric clutch cutoff on loader lever; AutoShift transmission standard		
Torque Converter	Single stage, dual phase with 1.92:1 stall ratio, 280 mm (11 in.)		
PowerShift Standard Transmission			
Maximum Travel Speeds With Standard Engine, Mechanical-Front-Wheel Drive (MFWD), and 21L-28 Rear Tires			
	<i>Forward</i>	<i>Reverse</i>	
Gear 1	6.0 km/h (3.7 mph)	6.7 km/h (4.2 mph)	
Gear 2	10.0 km/h (6.2 mph)	11.2 km/h (7.0 mph)	
Gear 3	24.6 km/h (15.3 mph)	27.4 km/h (17.0 mph)	
Gear 4	36.9 km/h (22.9 mph)	—	
Axles			
Axle Oscillation, Stop to Stop, Front Axle	18 deg.		
Axle Ratings	<i>Front</i>	<i>Rear</i>	
SAE J43	9000 kg (19,800 lb.)	11 500 kg (25,400 lb.)	
Dynamic	12 500 kg (27,600 lb.)	14 000 kg (30,900 lb.)	
Static	32 000 kg (70,500 lb.)	32 000 kg (70,500 lb.)	
Ultimate	48 000 kg (105,800 lb.)	48 000 kg (105,800 lb.)	
Differentials			
MFWD Axle	Automatic, limited-slip traction control		
Rear Axle	Foot actuated, hydraulically engaged mechanical lock		
Steering (ISO 5010)			
Axle	<i>MFWD</i>	<i>Non-Powered Front</i>	
Curb-Turning Radius			
With Brakes	3.99 m (13 ft. 1 in.)	3.98 m (13 ft. 1 in.)	
Without Brakes	4.58 m (15 ft. 0 in.)	4.57 m (15 ft. 0 in.)	
Bucket-Clearance Circle			
With Brakes	11.42 m (37 ft. 6 in.)	11.43 m (37 ft. 6 in.)	
Without Brakes	12.30 m (40 ft. 4 in.)	12.31 m (40 ft. 5 in.)	
Steering Wheel Turns (lock to lock, flow amplified)	2.7 to 4.4	2.9 to 4.7	
MFWD Axle	Heavy duty, outboard planetary final drives distribute shock loads over 3 gears		
Rear Axle	Heavy duty, inboard planetary final drives distribute shock loads over 3 gears		
Brakes (ISO 3450)			
Service	Full power, hydraulic wet disc, mounted inboard, self-adjusting and self-equalizing		
Parking	Spring applied, hydraulically released, wet, multi-disc, independent of service brakes with electric switch control		
Hydraulics			
Main Pump	Pressure compensated load sensing (PCLS), axial-piston pump		
Pump Flow at 2,200 rpm			
Backhoe	198 L/m (52.3 gpm)		
Loader	198 L/m (52.3 gpm)		
System Relief Pressure, Backhoe and Loader			
Backhoe	24 993 kPa (3,625 psi)		
Lift Mode	26 890 kPa (3,900 psi)		
Loader	24 993 kPa (3,625 psi)		

710 P-TIER BACKHOE LOADER SPECIFICATIONS

710

P

While general information, pictures, and descriptions are provided, some illustrations and text may include product options and accessories NOT AVAILABLE in all regions, and in some countries products and accessories may require modifications or additions to ensure compliance with the local regulations of those countries.

Hydraulics <i>(continued)</i>		710 P-TIER	
Controls			
Backhoe	Pilot controls with pattern select standard; electrohydraulic (EH) auxiliary functions optional		
Loader	Single-lever control with electric clutch cutoff switch and MFWD (momentary) standard; single-lever control with electric clutch cutoff switch, EH proportional auxiliary roller, MFWD (momentary), and transmission quick-shift optional		
Cylinders			
Heat-treated, chrome-plated, polished rods; hardened steel (replaceable bushings) pivot pins			
	<i>Bore</i>	<i>Rod Diameter</i>	<i>Stroke</i>
Loader Boom (2)	100 mm (3.94 in.)	56 mm (2.20 in.)	805 mm (31.69 in.)
Loader Bucket (1)	110 mm (4.33 in.)	56 mm (2.20 in.)	672 mm (26.44 in.)
Backhoe Boom (1)	160 mm (6.30 in.)	95 mm (3.74 in.)	944 mm (37.17 in.)
Backhoe Crowd (1)	140 mm (5.51 in.)	85 mm (3.35 in.)	792 mm (31.16 in.)
Backhoe Bucket (1)	110 mm (4.33 in.)	70 mm (2.76 in.)	939 mm (36.97 in.)
Backhoe Swing (2)	110 mm (4.33 in.)	56 mm (2.20 in.)	308 mm (12.13 in.)
Backhoe Extendable Dipperstick (1)	80 mm (3.15 in.)	45 mm (1.77 in.)	1372 mm (54.00 in.)
Backhoe Stabilizer, Extended (2)	115 mm (4.53 in.)	63 mm (2.48 in.)	588 mm (23.15 in.)
Non-Powered Axle (1)	75 mm (2.95 in.)	45 mm (1.77 in.)	240 mm (9.45 in.)
MFWD (1)	75 mm (2.95 in.)	50 mm (1.97 in.)	260 mm (10.24 in.)
Electrical			
Voltage	12 volt		
Alternator Rating	160 amp		
Lights	10 halogen: 4 front, 4 rear, and 2 side docking (32,500 candlepower each); turn signals and flashers: 2 front and 2 rear; stop and taillights; and 2 rear reflectors; factory-installed option for 2 LED spotlights and 8 LED floodlights in lieu of standard halogen light package		
Operator Station			
Type (ISO 3471)	Fully enclosed cab, isolation mounted, ROPS/FOPS, left/right access, with molded roof; optional canopy		
Tires/Wheels			
	<i>Front</i>	<i>Rear</i>	
Non-Powered Front Axle	12.5/80-18 F3 (16)	21L-28 R4 (18)	
	14.5/75-16.1 F3 (16)	20.5-25 L-3 (20)	
With MFWD	15-19.5 R4 (12)	21L-28 R4 (18)	
	15-19.5 R4 (12)	20.5-25 L-3 (20)	
Serviceability			
Refill Capacities			
Cooling System			
Cab	28.4 L (30.0 qt.)		
Canopy	26.4 L (27.9 qt.)		
Rear Axle	25.0 L (26.4 qt.)		
Engine Oil (including vertical spin-on filter)	13.0 L (13.7 qt.)		
Torque Converter and Transmission	15.1 L (16.0 qt.)		
Fuel Tank (with ground-level fueling)	174.1 L (46.0 gal.)		
Diesel Exhaust Fluid (DEF) Tank	13.7 L (3.6 gal.)		
Hydraulic System	174.1 L (46.0 gal.)		
Hydraulic Reservoir	50.1 L (13.2 gal.)		
MFWD Housing			
Axle	15.0 L (15.9 qt.)		
Planetary (each)	2.2 L (2.3 qt.)		
Operating Weights			
With Full Fuel Tank, 75-kg (165 lb.) Operator, Standard Equipment, Canopy, and 272-kg (600 lb.) Counterweight	11 698 kg (25,790 lb.)		Optional Components (weight difference between base equipment and option)
Typical With Cab, Extendable Dipperstick, and 680-kg (1,500 lb.) Counterweight	12 691 kg (27,979 lb.)		Cab 254 kg (560 lb.)
			MFWD With Tires 274 kg (604 lb.)
			Extendable Dipperstick 331 kg (730 lb.)
			Front Loader Coupler 93 kg (205 lb.)

710 P-TIER

While general information, pictures, and descriptions are provided, some illustrations and text may include product options and accessories NOT AVAILABLE in all regions, and in some countries products and accessories may require modifications or additions to ensure compliance with the local regulations of those countries.

Overall Dimensions		710 P-TIER	
A	Ground Clearance, Minimum	356 mm (14 in.)	
B	Overall Length, Transport	8.23 m (27 ft. 0 in.)	
C	Width Over Tires	2.37 m (7 ft. 9 in.)	
D	Height to Top of ROPS/Cab	2.97 m (9 ft. 9 in.)	
E	Length From Axle to Axle		
	Non-Powered Front Axle	2.58 m (8 ft. 5 in.)	
	MFWD Axle	2.55 m (8 ft. 4 in.)	

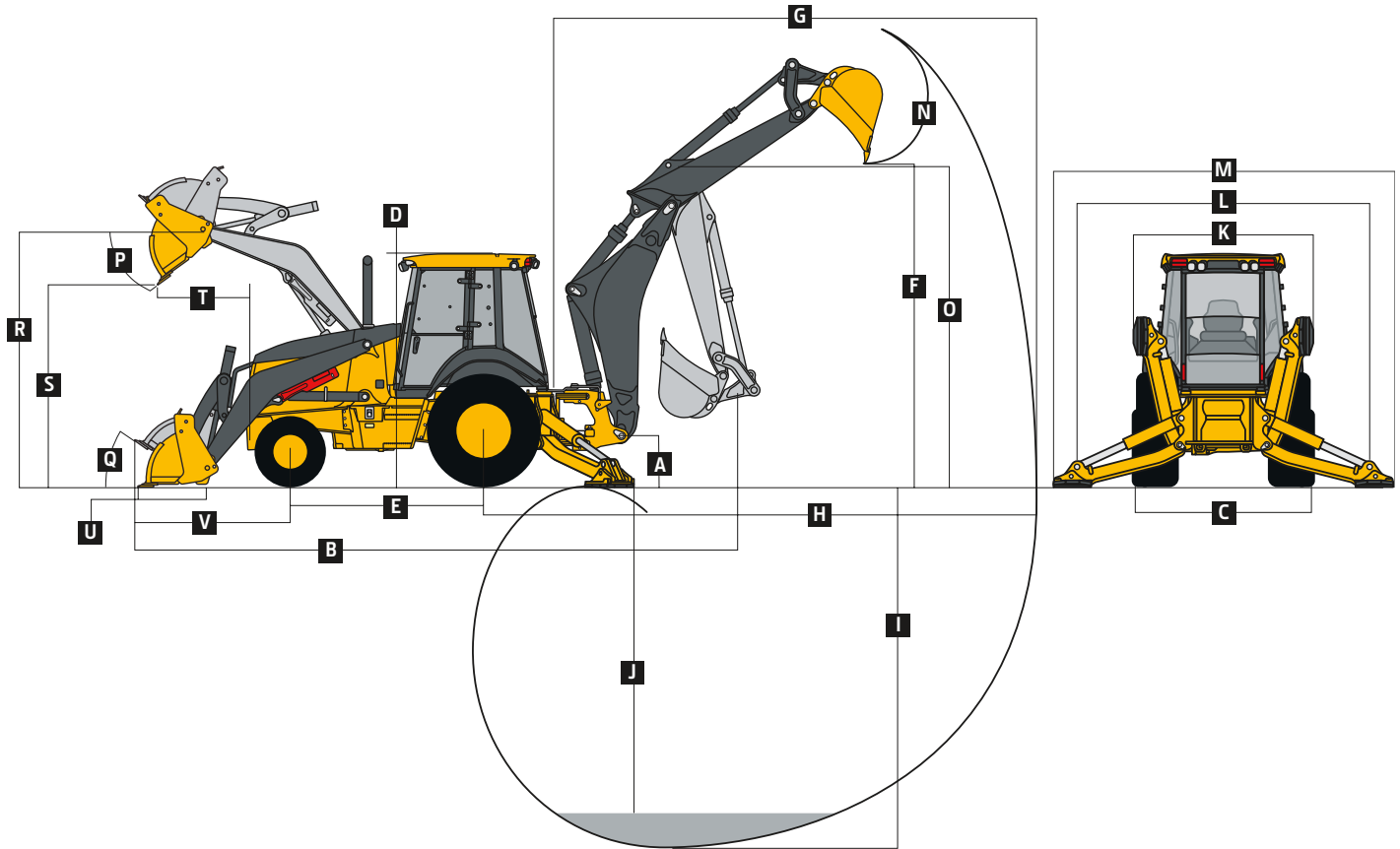

Backhoe Dimensions and Performance

Backhoe specifications are with 610-mm x 0.31-m³ (24 in. x 11 cu. ft.) bucket; dipper lift specs are with a boom angle of 65 deg.

Bucket Range	610–914 mm (24–36 in.)
Digging Force	
Bucket Cylinder	78.4 kN (17,622 lb.)
Lift Mode	84.3 kN (18,959 lb.)
Crowd Cylinder	53.4 kN (11,999 lb.)
Lift Mode	57.4 kN (12,910 lb.)
Swing Arc	180 deg.
Operator Control	Pilot control

	With Optional Extendable Dipperstick		
	With Standard Backhoe	Retracted	Extended
F Loading Height, Truck Loading Position	4.45 m (14 ft. 7 in.)	4.49 m (14 ft. 9 in.)	5.35 m (17 ft. 6 in.)
G Reach from Center of Swing Pivot	6.84 m (22 ft. 5 in.)	6.84 m (22 ft. 5 in.)	8.15 m (26 ft. 9 in.)
H Reach from Center of Rear Axle	8.11 m (26 ft. 7 in.)	8.11 m (26 ft. 7 in.)	9.42 m (30 ft. 11 in.)
I Digging Depth (SAE maximum)	5.26 m (17 ft. 3 in.)	5.26 m (17 ft. 3 in.)	6.63 m (21 ft. 9 in.)
J Digging Depth (SAE)			
610-mm (2 ft.) Flat Bottom	5.25 m (17 ft. 3 in.)	5.25 m (17 ft. 2 in.)	6.62 m (21 ft. 8 in.)
2440-mm (8 ft.) Flat Bottom	4.96 m (16 ft. 3 in.)	4.96 m (16 ft. 3 in.)	6.40 m (21 ft. 0 in.)
K Stabilizer Width, Transport	2.41 m (7 ft. 11 in.)	2.41 m (7 ft. 11 in.)	2.41 m (7 ft. 11 in.)
L Stabilizer Spread, Operating	3.99 m (13 ft. 1 in.)	3.99 m (13 ft. 1 in.)	3.99 m (13 ft. 1 in.)
M Stabilizer Overall Width, Operating	4.65 m (15 ft. 3 in.)	4.65 m (15 ft. 3 in.)	4.65 m (15 ft. 3 in.)
N Bucket Rotation	190 deg.	190 deg.	190 deg.
O Transport Height	4.23 m (13 ft. 10 in.)	4.23 m (13 ft. 10 in.)	4.23 m (13 ft. 10 in.)

Loader Dimensions and Performance

P	Bucket Dump Angle, Maximum	45 deg.
Q	Rollback Angle at Ground Level	40 deg.

While general information, pictures, and descriptions are provided, some illustrations and text may include product options and accessories NOT AVAILABLE in all regions, and in some countries products and accessories may require modifications or additions to ensure compliance with the local regulations of those countries.

710 P-TIER

Loader Dimensions and Performance (continued) 710 P-TIER			
	Standard-duty	Standard-duty	Multipurpose
Bucket Capacity	1.24 m ³ (1.62 cu. yd.)	1.43 m ³ (1.87 cu. yd.)	1.00 m ³ (1.31 cu. yd.)
Width	2464 mm (97 in.)	2464 mm (97 in.)	2451 mm (96 in.)
Weight	830 kg (1,830 lb.)	866 kg (1,909 lb.)	995 kg (2,193 lb.)
Breakout Force	73.6 kN (16,539 lb.)	70.5 kN (15,853 lb.)	73.3 kN (16,474 lb.)
Lift Capacity, Full Height	4475 kg (9,866 lb.)	4239 kg (9,346 lb.)	4081 kg (8,998 lb.)
R Height to Bucket Hinge Pin, Maximum	3.73 m (12 ft. 3 in.)	3.73 m (12 ft. 3 in.)	3.73 m (12 ft. 3 in.)
S Dump Clearance, Bucket at 45 deg.	2.89 m (9 ft. 6 in.)	2.81 m (9 ft. 3 in.)	2.92 m (9 ft. 7 in.)
T Reach at Full Height, Bucket at 45 deg.	768 mm (30.2 in.)	849 mm (33.4 in.)	763 mm (30 in.)
U Digging Depth Below Ground, Bucket Level	157 mm (6.2 in.)	157 mm (6.2 in.)	141 mm (5.5 in.)
V Length From Front Axle Centerline to Bucket Cutting Edge	2.14 m (7 ft. 0 in.)	2.26 m (7 ft. 5 in.)	2.11 m (6 ft. 11 in.)

Lift Capacity With Quick-Coupler Forks [see line art below]	
Hydraulic Capacity	1219-mm (48 in.) Tines
A ¹ Maximum Height	2632 kg (5,803 lb.)
B ¹ Maximum Reach	4378 kg (9,651 lb.)
C ¹ At Ground Line	6057 kg (13,353 lb.)
D ¹ Below Ground Line	140 mm (5.5 in.)

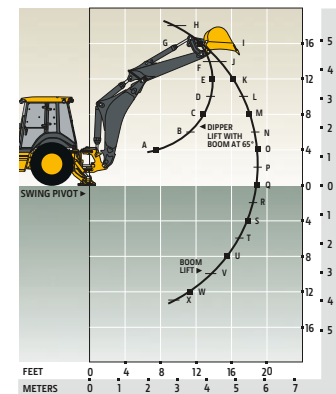
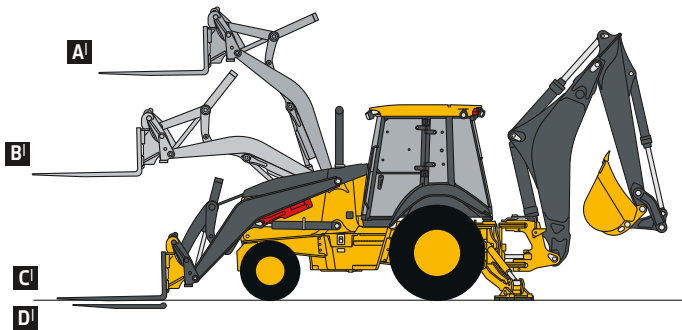

With Standard Dipperstick

Lift Capacities [see line art at right]
Lift capacities are over-end values in kg (lb.). Figures listed are 100% of the maximum lift force available.

With Standard Dipperstick		With 1.37-m (4 ft. 6 in.) Extendable Dipperstick, Retracted		With 1.37-m (4 ft. 6 in.) Extendable Dipperstick, Extended	
Standard Lift	Lift Mode	Standard Lift	Lift Mode	Standard Lift	Lift Mode
A	9519 kg (20,986 lb.)	9519 kg (20,986 lb.)	9343 kg (20,597 lb.)	9343 kg (20,597 lb.)	5431 kg (11,973 lb.)
B	5244 kg (11,561 lb.)	5506 kg (12,140 lb.)	5109 kg (11,262 lb.)	5290 kg (11,662 lb.)	3397 kg (7,488 lb.)
C	4492 kg (9,903 lb.)	4732 kg (10,432 lb.)	4344 kg (9,578 lb.)	4520 kg (9,965 lb.)	2914 kg (6,425 lb.)
D	4087 kg (9,010 lb.)	4419 kg (9,743 lb.)	3932 kg (8,669 lb.)	4229 kg (9,323 lb.)	2659 kg (5,862 lb.)
E	3718 kg (8,197 lb.)	4022 kg (8,866 lb.)	3557 kg (7,843 lb.)	3860 kg (8,510 lb.)	2479 kg (5,466 lb.)
F	3219 kg (7,096 lb.)	3483 kg (7,679 lb.)	3050 kg (6,724 lb.)	3313 kg (7,304 lb.)	2324 kg (5,123 lb.)
G	2304 kg (5,079 lb.)	2497 kg (5,505 lb.)	2122 kg (4,679 lb.)	2314 kg (5,102 lb.)	2164 kg (4,771 lb.)
H	2500 kg (5,512 lb.)	2717 kg (5,990 lb.)	2291 kg (5,052 lb.)	2508 kg (5,530 lb.)	1974 kg (4,351 lb.)
I	2572 kg (5,670 lb.)	2805 kg (6,184 lb.)	2348 kg (5,177 lb.)	2581 kg (5,691 lb.)	1719 kg (3,790 lb.)
J	2532 kg (5,581 lb.)	2766 kg (6,099 lb.)	2301 kg (5,073 lb.)	2536 kg (5,590 lb.)	1340 kg (2,954 lb.)
K	2465 kg (5,434 lb.)	2697 kg (5,947 lb.)	2230 kg (4,916 lb.)	2462 kg (5,428 lb.)	1625 kg (3,583 lb.)
L	2391 kg (5,271 lb.)	2620 kg (5,776 lb.)	2152 kg (4,744 lb.)	2381 kg (5,250 lb.)	1679 kg (3,701 lb.)
M	2316 kg (5,105 lb.)	2541 kg (5,602 lb.)	2074 kg (4,573 lb.)	2300 kg (5,070 lb.)	1685 kg (3,714 lb.)
N	2243 kg (4,945 lb.)	2464 kg (5,433 lb.)	1999 kg (4,407 lb.)	2220 kg (4,895 lb.)	1669 kg (3,680 lb.)
O	2173 kg (4,791 lb.)	2391 kg (5,271 lb.)	1927 kg (4,248 lb.)	2145 kg (4,728 lb.)	1644 kg (3,624 lb.)
P	2107 kg (4,646 lb.)	2321 kg (5,118 lb.)	1859 kg (4,098 lb.)	2073 kg (4,570 lb.)	1613 kg (3,556 lb.)
Q	2045 kg (4,509 lb.)	2256 kg (4,974 lb.)	1794 kg (3,956 lb.)	2005 kg (4,421 lb.)	1579 kg (3,482 lb.)
R	1987 kg (4,381 lb.)	2195 kg (4,840 lb.)	1734 kg (3,823 lb.)	1942 kg (4,282 lb.)	1545 kg (3,406 lb.)
S	1934 kg (4,263 lb.)	2139 kg (4,716 lb.)	1678 kg (3,698 lb.)	1883 kg (4,152 lb.)	1511 kg (3,331 lb.)
T	1884 kg (4,154 lb.)	2088 kg (4,604 lb.)	1625 kg (3,583 lb.)	1829 kg (4,033 lb.)	1477 kg (3,257 lb.)
U	1841 kg (4,058 lb.)	2044 kg (4,506 lb.)	1578 kg (3,479 lb.)	1781 kg (3,927 lb.)	1445 kg (3,185 lb.)
V	1805 kg (3,979 lb.)	2009 kg (4,429 lb.)	1537 kg (3,388 lb.)	1741 kg (3,838 lb.)	1414 kg (3,117 lb.)
W	1786 kg (3,937 lb.)	1995 kg (4,397 lb.)	1509 kg (3,327 lb.)	1718 kg (3,787 lb.)	1385 kg (3,054 lb.)
X	1794 kg (3,954 lb.)	2009 kg (4,429 lb.)	1508 kg (3,325 lb.)	1723 kg (3,799 lb.)	1359 kg (2,995 lb.)
Y	—	—	—	—	1335 kg (2,943 lb.)
Z	—	—	—	—	1316 kg (2,900 lb.)
a	—	—	—	—	1302 kg (2,871 lb.)
b	—	—	—	—	1299 kg (2,865 lb.)
c	—	—	—	—	1322 kg (2,914 lb.)
d	—	—	—	—	1453 kg (3,202 lb.)

Lift capacities are over end with stabilizers down and tires tangent to ground.

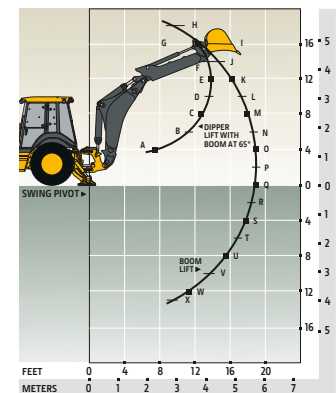

With Extendable Dipperstick, Retracted

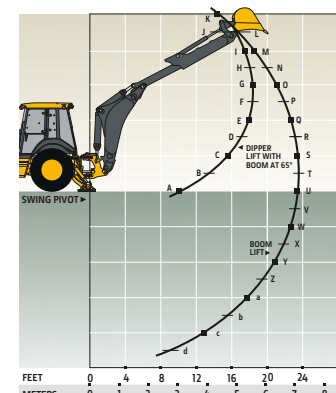

With Extendable Dipperstick, Extended

Additional equipment

Key: ● Standard ▲ Optional or special

See your John Deere dealer for further information.

710 P Engine

- Coolant recovery tank with low-level indicator
- Foldout, hinged cooling system
- Serpentine belt with automatic belt tensioner
- Electronically controlled, variable-rate suction-type cooling fan
- Self-cleaning exhaust aftertreatment system
- ▲ Chrome exhaust extension
- Glow plugs
- 1,000-watt electric engine coolant heater
- Electronic fuel lift pump

Powertrain

- PowerShift™ transmission: Torque converter with twist-grip Transmission Control Lever (TCL) and neutral safety switch interlock (1st through 4th gears)
- AutoShift transmission
- Transmission oil cooler
- ▲ Transmission remote oil-sampling port
- Differential lock, electric foot actuated, protection on/off (software enabled)
- Differential lock, electric foot actuated
- Auto shutdown
- Planetary final drives
- Power-assisted hydraulic service brakes (conform to ISO 3450): Inboard, wet multi-disc, self-adjusting and self-equalizing

710 P Powertrain (continued)

- Parking/emergency brake with electric switch control (conforms to ISO 3450): Spring applied, hydraulically released wet multi-disc / Independent of service brakes
- Hydrostatic power steering with emergency manual mode
- ▲ Non-powered front axle
- Mechanical-front-wheel drive (MFWD) with traction-control limited-slip differential: Electric on/off control / Sealed axle
- Automatic MFWD braking

Backhoe

- Lift mode
- Precision mode
- Standard dipperstick digging depth
- 5.26 m (17 ft. 3 in.)
- Extendable dipperstick extension
- ▲ 1.37 m (4 ft. 6 in.)
- 2-lever pilot controls with pattern-selection feature
- Backhoe transport lock lever
- Swing lock pin stored in operator's station
- Stabilizers with 2-direction anti-drift valves
- Extended (long) stabilizers with reversible pads
- ▲ Auxiliary backhoe valve with 1-way flow for hammers and compactors with plumbing
- ▲ Auxiliary backhoe valve with 1- and 2-way flow for swinggers, thumbs, augers, etc. (plumbing not included)

710 P Loader*

- Loader bucket anti-spill (rollback)
- Return-to-dig feature
- Single-lever control with electric clutch disconnect
- Bucket-level indicator
- Loader boom service lock
- Loader valve with integrated anti-drift checks for hydraulic cylinders controlling loader boom up and bucket dump
- ▲ Auxiliary loader hydraulics with single control lever with EH auxiliary control (MFWD and clutch disconnect)
- ▲ Hydraulic coupler for buckets, forks, etc.
- Auto ride control

Hydraulic System

- 198-L/m (52.3 gpm) axial-piston pump, pressure-compensated load-sensing (PCLS) system
- Auto-idle
- Economy mode
- Dedicated hydraulic reservoir

Electrical System

- 12-volt system
- 160-amp alternator
- Dual batteries with 350-min. reserve capacity and 1,900 CCA
- ▲ Remote jump posts and battery disconnect

*See dealer for range of heavy-duty (HD), multi-purpose, and coupler buckets and forks.

While general information, pictures, and descriptions are provided, some illustrations and text may include product options and accessories NOT AVAILABLE in all regions, and in some countries products and accessories may require modifications or additions to ensure compliance with the local regulations of those countries.

Net engine power is with standard equipment including air cleaner, exhaust system, alternator, and cooling fan at test conditions specified per ISO 9249. Specifications and design are subject to change without notice. Wherever applicable, specifications are in accordance with ISO standards. Except where otherwise noted, these specifications are based on a unit with 21L-28-in. 18PR (R4) tubeless rear and 15-19.5-in. 12PR (R4) front tires, and 1.24-m³ (1.62 cu. yd.) loader bucket.

Additional equipment *(continued)*

Key: ● Standard ▲ Optional or special

See your John Deere dealer for further information.

710 P Lights

- Halogen lights (10), 32,500 candlepower each (4 front driving/working, 4 rear working, and 2 side docking)
- Turn signal/flashing (2 front and 2 rear)
- Rear stop and tail (2)
- ▲ LED light package

Operator's Station

- Modular-design ROPS/FOPS (Level 2) canopy with molded roof (meets ISO 3449 and ISO 3471/SAE J1040): Isolation mounted
- Molded floor mats (with pilot controls only)
- 12-volt outlet
- Lockable right-side storage
- ▲ Lockable left-hand storage with cup holders
- ▲ Interior front-view mirror
- ▲ Outside rearview mirrors
- Rotary-dial hand throttle
- Suspended foot throttle
- Mechanical-suspension seat, cloth cover
- ▲ Air-suspension heated seat (with cab only)
- ▲ Air-suspension vinyl seat
- Tilt steering, infinitely adjustable (with cab only)
- ▲ Tilt steering, infinitely adjustable (with canopy and quarter cab)
- Keyless start

710 P Operator's Station *(continued)*

- Machine security (enabled through monitor)
- Digital display of engine hours, engine rpm, and system voltage
- Sealed-switch module (SSM)
- Multi-function lever: Turn signals / Windshield wipers / Some light functionality
- Monitor system with audible and visual warnings: Engine air restriction / Low alternator voltage / Engine oil pressure / Hydraulic filter restriction / Parking brake on/off / Aftertreatment temperature / Transmission fluid temperature / Fuel / Hour meter / Machine diagnostic information via 4-push-button/LCD operator interface
- **Canopy:** Mechanical-suspension deluxe vinyl swivel seat with lumbar adjustment and armrests (fully adjustable)
- ▲ **Cab with Dual Doors and A/C:** Mechanical-suspension deluxe fabric swivel seat with lumbar adjustment / Headliner, dome light, left and right cab doors, tinted safety glass, windshield wipers (1 rear and 1 front), front windshield washer, fresh-air intake, and heater/defroster/pressurizer (11.7-kW [40,000 Btu/h] heater) / A/C (7.6-kW [26,000 Btu/h] output and CFC-free R134a refrigerant)

710 P Operator's Station *(continued)*

- ▲ AM/FM/weather-band (WB) radio (with cab only)
 - ▲ Premium radio package (with cab only; includes additional 12-volt and USB outlets)
- ## Overall Vehicle
- 1-piece unitized construction mainframe
 - Vehicle tie-downs (2 front and 2 rear)
 - Remote grease bank for front axle
 - Front counterweight – 272 kg (600 lb.) or 680 kg (1,500 lb.)
 - Fuel tank, 174.1 L (46 gal.), ground-level fueling
 - 2-position easy-tilt hood
 - Extended grille frame
 - Toolbox with padlock hasp
 - Vandal protection for locking monitor, engine hood, toolbox, hydraulic reservoir, and fuel tank
 - Reverse warning alarm
 - Dent-resistant full-coverage rear fenders
 - ▲ Backhoe boom-protection plate
 - JDLink™ wireless communication system (available in specific countries; see your dealer for details)
 - ▲ HD stabilizer pads

While general information, pictures, and descriptions are provided, some illustrations and text may include product options and accessories NOT AVAILABLE in all regions, and in some countries products and accessories may require modifications or additions to ensure compliance with the local regulations of those countries.

Net engine power is with standard equipment including air cleaner, exhaust system, alternator, and cooling fan at test conditions specified per ISO 9249. Specifications and design are subject to change without notice. Wherever applicable, specifications are in accordance with ISO standards. Except where otherwise noted, these specifications are based on a unit with 21L-28-in. 18PR (R4) tubeless rear and 15-19.5-in. 12PR (R4) front tires, and 1.24-m³ (1.62 cu. yd.) loader bucket.



MB710PAU (23-03)



JOHN DEERE