

CONSTRUCTION EQUIPMENT  
**ATTACHMENTS**



**JOHN DEERE**

EXCAVATORS / CRAWLER DOZERS / WHEEL LOADERS /  
MOTOR GRADERS / TRACTOR LOADERS / BACKHOE LOADERS



# **BOTTOM-LINE BOOSTERS.**

**IT'S EASY TO GET ATTACHED.**

The complete line of John Deere mid-size and large excavators, crawler dozers, four-wheel-drive loaders, tractor loaders, and backhoe loaders can accomplish even more than you might imagine when paired with our highly capable and versatile construction equipment attachments. From ground-engaging rippers and powerful plate compactors to heavy-duty hydraulic hammers and firm-grasping forks, we've got the durable attachments you need to help you break through and build up your bottom line.



**INCREASE  
VERSATILITY**

**WITH JOHN DEERE  
ATTACHMENTS**

## **INDEX**

Plate Compactors .....	3	Hydraulic Hammers .....	14-15
engcon® Tiltrotators .....	4	Rotary Cutter .....	16
Rippers/Scarifiers .....	5	Thumbs .....	17
Mulching Heads .....	6	Couplers .....	18-21
Winches .....	7	Forks .....	22-23
Buckets .....	8-13		

# PLATE COMPACTORS

PC10 | PC16 | PC23 | PC40

## FEATURES AND SPECIFICATIONS

- Large eccentric weight that is offset from the motor shaft helps enable high-impulse forces, for exceptional compaction rates.
- Designed specifically for trench-, slope-, and excavator-compaction applications, durable plate compactors can also be used for driving pilings, pipes, and fence and guardrail posts.
- Plate compactors are durably constructed to absorb shocks and vibration, maximizing attachment stability and compaction efficiency.
- Eccentric housing has been designed to enclose and protect the motor.
- Standard four-function valve capably controls flow, anti-cavitation, pressure, and oil-flow direction.
- Oil-splash bearing provides maintenance-free lubrication without the need for greasing.
- These plate compactors are optimized to work with select models of John Deere G-Series and P-Tier Excavators. They're also compatible with many competitive models.

Model	PC10	PC16	PC23	PC40
<b>Compactor Weight</b>	403 kg (888 lb.)	710 kg (1,565 lb.)	1010 kg (2,213 lb.)	2220 kg (4,888 lb.)
<b>Operating Weight*</b> (includes mounting bracket)	431 kg (950 lb.)	830 kg (1,818 lb.)	1250 kg (2,754 lb.)	2560 kg (5,623 lb.)
<b>Impact Rate</b>	2,000 cycles/min.	2,100 cycles/min.	2,100 cycles/min.	2,100 cycles/min.
<b>Impact Force</b>	35.6 kN (8,000 lbf.)	71.2 kN (16,000 lbf.)	106.8 kN (24,000 lbf.)	178.0 kN (40,000 lbf.)
<b>Compactor Plate Size</b>	610 x 710 mm (24 x 28 in.)	737 x 813 mm (29 x 32 in.)	864 x 914 mm (34 x 36 in.)	1066 x 1219 mm (42 x 48 in.)
<b>Compactor Plate Area</b>	0.43 m <sup>2</sup> (4.6 sq. ft.)	0.6 m <sup>2</sup> (6 sq. ft.)	0.79 m <sup>2</sup> (8.5 sq. ft.)	1.3 m <sup>2</sup> (14 sq. ft.)
<b>Overall Height</b>				
With Bracket	Options vary	1143.0 mm (45.0 in.)	1219.2 mm (48.0 in.)	1303.02 mm (51.3 in.)
Without Bracket	648.0 mm (25.5 in.)*	812.8 mm (32.0 in.)	889.0 mm (35.0 in.)	972.82 mm (38.3 in.)
<b>Overall Width</b>				
Mounting Bracket	460.0 mm (18.1 in.)	510.0 mm (20.0 in.)	570.0 mm (22.4 in.)	890.0 mm (35.0 in.)
Main Body	610.0 mm (24.0 in.)	740.0 mm (29.0 in.)	860.0 mm (34.0 in.)	1070.0 mm (42.0 in.)
<b>Sound Power Level (estimated), LWA</b>	106 dB	108 dB	108 dB	110 dB
<b>Hydraulics</b>				
Hydraulic Flow Required	76–91 l/min (20–24 gpm)	113.6 l/min (30 gpm)	177.9 l/min (47 gpm)	235.0 l/min (62 gpm)
Maximum Operating Pressure	13.8 MPa (2,000 psi)	20.7 MPa (3,000 psi)	15.2 MPa (2,200 psi)	15.2 MPa (2,200 psi)
Maximum Machine Auxiliary Relief	15.2 MPa (2,200 psi)	25.2 MPa (3,650 psi)	19.7 MPa (2,850 psi)	19.7 MPa (2,850 psi)
Pressure Line Connection (IN)	M ORFS -12	M ORFS -16	M ORFS -16	M ORFS -20
Return Line Connection	M ORFS -12	M ORFS -16	M ORFS -16	M ORFS -20
<b>Mounting System (bracket and hoses)</b>	Optional	Optional	Optional	Optional
<b>Vehicle Compatibility</b>	John Deere 75G, 85G, 130G, 135G, 160G LC-200G with auxiliary hydraulics	John Deere 160G LC-200G/ with auxiliary hydraulics	John Deere 210G-380 P-Tier with auxiliary hydraulics	John Deere 350-380 P-Tier with auxiliary hydraulics
<b>Allowed Carrier Weight</b>	4-14 tonne (9,000-30,000 lb.)	9-20.5 tonne (20,000-45,000 lb.)	16-54 tonne (35,000-120,000 lb.)	35-70 tonne (77,000-150,000 lb.)

\*Weight and dimensions may vary due to machine-specific mounting adapters.

[Learn more about Plate Compactors](#)

[Back to Table of Contents](#)



# ENGCON<sup>®</sup> TILTROTATORS

EC209 | EC214 | EC219 | EC226 | EC233

## FEATURES AND SPECIFICATIONS

- With the engcon automatic coupler and tiltrotator system, operators can rotate attachments 360 degrees and tilt them up to 45 degrees side to side. Having the ability to rotate and tilt the attachment boosts versatility and precision when undermining existing utilities. Being able to grade and backfill complex contours also reduces manual labor for landscapers and site developers.
- For maximum breakout force or when lifting, the operator can simply disconnect the tiltrotator via the automatic quick-coupler, then reconnect it to backfill, maximizing versatility.
- The quick-coupler system, EC-Oil allows operators to change attachments equipped with hydraulic and electrical connections without leaving the cab of the machine, increasing productivity and efficiency.
- These engcon tiltrotators are optimized to work with John Deere 75G–345G LC Excavators.

[Learn more about engcon Tiltrotators](#)

[Back to Table of Contents](#)

Model	EC209	EC214	EC219	EC226	EC233
<b>Total Width</b>	548.6 mm (21.6 in.)	622.3 mm (24.5 in.)	706.1 mm (27.8 in.)	767.1 mm (30.2 in.)	886.4 mm (34.9 in.)
<b>Total Length</b>	561.3 mm (22.1 in.)	665.4 mm (26.2 in.)	736.6 mm (29.0 in.)	759.4 mm (29.9 in.)	878.8 mm (34.6 in.)
<b>Construction Height</b>	from 424.2 mm (16.7 in.)	from 457.2 mm (18.0 in.)	from 480.1 mm (18.9 in.)	from 500.4 mm (19.7 in.)	from 673.1 mm (26.5 in.)
<b>Weight</b>	286.4 kg (631.4 lb.)	384.2 kg (847.0 lb.)	446.1 kg (983.4 lb.)	630.7 kg (1,390.4 lb.)	810.3 kg (1,786.4 lb.)
<b>Tilt Range</b>	±45 deg.	±45 deg.	±45 deg.	±45 deg.	±45 deg.
<b>Maximum Hydraulic Pressure</b>	22 000 kPa (3,200 psi)	22 000 kPa (3,200 psi)	22 000 kPa (3,200 psi)	22 000 kPa (3,200 psi)	25 000 kPa (3,626 psi)
<b>Standard Mountings</b>	QS45, QS50	QS45, QS50, QS60	QS60	QS70	QS70, QS80, S2
<b>Maximum Bucket Width Recommended by engcon</b>	1295 mm (51 in.)	1600 mm (63 in.)	1702 mm (67 in.)	2007 mm (79 in.)	2210 mm (87 in.)
<b>Maximum Torque</b>	74 kNm (54,580 lb.-ft.)	126 kNm (92,933 lb.-ft)	186 kNm (137,187 lb.-ft.)	270 kNm (199,142 lb.-ft)	340 kNm (250,771 lb.-ft)
<b>Recommended Carrier Weight</b>	5987–8981 kg (13,200–19,800 lb.)	8981–14 016 kg (19,800–30,900 lb.)	14 016–19 006 kg (30,900–41,900 lb.)	19 006–25 991 kg (41,900–57,300 lb.)	23 995–33 022 kg (52,900–72,800 lb.)
<b>Vehicle Compatibility</b>	75G, 85G	130G, 135G	160G LC, 190G W, 200G	210G LC, 245G LC	250G LC, 300G LC, 345G LC
Requires installation of additional coupler system and tiltrotator controls.					

# RIPPERS/SCARIFIERS



## FEATURES AND SPECIFICATIONS

- The added weight of a rear ripper on a crawler dozer can significantly enhance the machine's grading performance and stability, both when equipped manually and with a grade-control system.
- Heavy-duty rear-mounted parallelogram rippers on motor graders include NeverGrease™ pin joints, hydraulic float, and integrated hitch. Choice of shanks/teeth from three up to five enables more controlled ground-engaging capacity.
- These rippers are optimized to work with John Deere crawler dozers and motor graders. They're also compatible with many competitive models.

Machine	Weight	Depth	Number of Pockets	Number of Shanks	Additional Features
<b>Crawler Loaders</b>					
655K	845 kg (1,863 lb.)	260 mm (10.2 in.)	3	3	—
755K	884 kg (1,950 lb.)	254 mm (10 in.)	3	3	—
<b>Dozers</b>					
450K	981 kg (2,163 lb.)	508 mm (20 in.)	5	3	—
550K	981 kg (2,163 lb.)	508 mm (20 in.)	5	3	—
650K	981 kg (2,163 lb.)	508 mm (20 in.)	5	3	—
700L	1444 kg (3,183 lb.)	563 mm (22 in.)	5	3	—
750L	1957 kg (4,314 lb.)	741 mm (29 in.)	3	3	—
<b>850L</b>					
3 Shank	2155 kg (4,750 lb.)	724 mm (28.5 in.)	3	3	—
5 Shank	2714 kg (5,983 lb.)	724 mm (28.5 in.)	5	5	—
950K	2669 kg (5,884 lb.)	650 mm (26 in.)	3	3	Adjustable pitch
<b>1050K</b>					
3 Shank	3793 kg (8,362 lb.)	1102 mm (43 in.)	3	3	Adjustable pitch
Single Shank	4586 kg (10,110 lb.)	780 mm (31 in.)	1	1	Adjustable pitch, hydraulic pin-puller option

Machine	Weight	Number of Ripper Pockets	Number of Ripper Shanks	Number of Scarifier Pockets	Number of Scarifier Shanks
<b>Motor Graders (all models)</b>					
Rear Ripper/Scarifier Combo With Hitch and Ripper Shanks	1139 kg (2,510 lb.)	5	3	9	—
Scarifier Shanks With Teeth	68 kg (150 lb.)	—	—	—	9
<b>Scarifier</b>					
Front Mount With Shanks and Teeth	831 kg (1,833 lb.)	—	—	9 / 2 pitch positions	5 / 2 pitch positions
Mid Mount With Shanks and Teeth	1481 kg (3,265 lb.)	—	—	11	11

Contact your local dealer for more information.

[Back to Table of Contents](#)



# MULCHING HEADS

ME36 | ME50

## FEATURES AND SPECIFICATIONS

- These mulchers are perfect for right-of-way maintenance, fire/fuel reduction, and clearing standing or felled trees and brush along fencerows, roadsides, waterways, and places that could otherwise be difficult to reach.
- Teeth may be sharpened, further increasing usable life.
- Split ring rotor design helps protect cutting tools from damaging impacts while working.
- Cubit knife-style teeth are easily flipped to create a brand-new cutting edge, doubling tool life.
- Single-bolt tool fastening is secure and easily serviced from the rear of the tool holder.
- Rotor and knife configuration cuts quickly, delivering better fuel economy by processing efficiently with less horsepower.
- These mulching heads are optimized to work with John Deere 75G and 85G Excavators.

[Learn more about Mulching Heads](#)

[Back to Table of Contents](#)

Model	ME36	ME50
<b>Width</b>		
Overall	1130 mm (44 in.)	1470 mm (58 in.)
Cutting	910 mm (36 in.)	1270 mm (50 in.)
<b>Height (without mount)</b>	690 mm (27 in.)	690 mm (27 in.)
<b>Length</b>	610 mm (24 in.)	610 mm (24 in.)
<b>Weight (without mount)</b>	390 kg (850 lb.)	480 kg (1,050 lb.)
<b>Cutting Tools, Standard</b>		
Type	Knife	Knife
Number	18	22
<b>Motor Type</b>	2-speed axial piston	2-speed axial piston
<b>Hydraulic Flow</b>		
Minimum	45 L/min. (12 gpm)	45 L/min. (12 gpm)
Maximum	98 L/min. (26 gpm)	98 L/min. (26 gpm)
<b>Maximum Operating Pressure</b>	28 mPa (4,000 psi)	28 mPa (4,000 psi)
<b>Hydraulic Connection</b>	12.7-mm (0.5 in.) quick-connect couplers with 9.525-mm (0.375 in.) case-drain coupler	12.7-mm (0.5 in.) quick-connect couplers with 9.525-mm (0.375 in.) case-drain coupler
<b>Vehicle Compatibility*</b>	75G, 85G	75G, 85G

\*Requires additional cab guarding and case-drain kit for operation.

# WINCHES

DEERE 4000



## FEATURES AND SPECIFICATIONS

- Two winch options are available for John Deere crawler dozers: power takeoff (PTO)/mechanical drive and hydraulic or hydrostatic drive:
  - Economical PTO/mechanical-drive winches are ideal for coarse oil-field, general forestry, and recovery work.
  - Hydrostatic models excel at cable plowing, pipeline installation, and precise load placement, and when variable speeds are required.
- The 4000 mechanical-drive winch comes in standard-speed and low-speed models, each delivering reliable line-pull performance depending on your need.
- Hydraulic winches have an open-loop configuration powered by the machine's hydraulic pump, while hydrostatic winches utilize a closed-loop design with a dedicated winch pump.
- Other available options to enhance winch productivity include a four-roller fairlead that helps prevent cable fraying and alignment during angle spooling, a rigid drawbar that extends beyond the winch to provide an anchor point during retrieval tasks, and cab screens for added protection.
- These winches are optimized to work with John Deere 450K, 550K, 650K, 700L, 750L, 850L, 950K, and 1050K Crawler Dozers.

Dozer Model / Winch Model	Bare Drum Maximum Line Pull	Bare Drum Maximum Line Speed	Drive Type	Weight
<b>450K</b>				
Deere 4000 Standard Speed	11 718 kg (25,833 lb.)	34.7 m/min. (114 ft./min.)	Mechanical/PTO	1093 kg (2,410 lb.)
Deere 4000 Low Speed	15 876 kg (35,000 lb.)	18.0 m/min. (59 ft./min.)	Mechanical/PTO	1093 kg (2,410 lb.)
H40R <sup>†</sup>	18,144 kg (40,000 lb.)	13.0 m/min. (41 ft./min.)	Hydraulic – Ripper	454 kg (1,000 lb.)
Carco H40*	18 140 kg (40,000 lb.)	44.0 m/min. (145 ft./min.)	Hydrostatic	623 kg (1,375 lb.)
Carco H50*	22 670 kg (50,000 lb.)	35.0 m/min. (116 ft./min.)	Hydrostatic	607 kg (1,340 lb.)
<b>550K</b>				
Deere 4000 Standard Speed	15 802 kg (34,837 lb.)	34.7 m/min. (114 ft./min.)	Mechanical/PTO	1093 kg (2,410 lb.)
Deere 4000 Low Speed	15 876 kg (35,000 lb.)	18.0 m/min. (59 ft./min.)	Mechanical/PTO	1093 kg (2,410 lb.)
H40R <sup>†</sup>	18,144 kg (40,000 lb.)	13.0 m/min. (41 ft./min.)	Hydraulic – Ripper	454 kg (1,000 lb.)
Carco H40*	18 140 kg (40,000 lb.)	44.0 m/min. (145 ft./min.)	Hydrostatic	623 kg (1,375 lb.)
Carco H50*	22 670 kg (50,000 lb.)	35.0 m/min. (116 ft./min.)	Hydrostatic	607 kg (1,340 lb.)
<b>650K</b>				
Deere 4000 Standard Speed	15 876 kg (35,000 lb.)	34.7 m/min. (114 ft./min.)	Mechanical/PTO	1093 kg (2,410 lb.)
Deere 4000 Low Speed	15 876 kg (35,000 lb.)	18.0 m/min. (59 ft./min.)	Mechanical/PTO	1093 kg (2,410 lb.)
H40R <sup>†</sup>	18,144 kg (40,000 lb.)	13.0 m/min. (41 ft./min.)	Hydraulic – Ripper	454 kg (1,000 lb.)
Carco H40*	18 140 kg (40,000 lb.)	44.0 m/min. (145 ft./min.)	Hydrostatic	623 kg (1,375 lb.)
Carco H50*	22 670 kg (50,000 lb.)	35.0 m/min. (116 ft./min.)	Hydrostatic	607 kg (1,340 lb.)
<b>700L</b>				
Deere 4000 Standard Speed	15 876 kg (35,000 lb.)	28.3 m/min. (93 ft./min.)	Mechanical/PTO	1093 kg (2,410 lb.)
Carco H50*	22 670 kg (50,000 lb.)	41.0 m/min. (135 ft./min.)	Hydrostatic	607 kg (1,340 lb.)
<b>750L</b>				
Carco H60 <sup>†</sup>	27 200 kg (60,000 lb.)	20.0 m/min. (67 ft./min.)	Hydraulic – Ripper	1195 kg (2,635 lb.)
H60 <sup>†</sup>	27 200 kg (60,000 lb.)	32.0 m/min. (105 ft./min.)	Hydraulic – Hi-Performance	1195 kg (2,635 lb.)
Carco H85 <sup>†</sup>	38 500 kg (85,000 lb.)	15.0 m/min. (50 ft./min.)	Hydraulic – Ripper	1238 kg (2,730 lb.)
H85 <sup>†</sup>	38 500 kg (85,000 lb.)	25.0 m/min. (82 ft./min.)	Hydraulic – Hi-Performance	1238 kg (2,730 lb.)
<b>850L</b>				
Carco H85 <sup>†</sup>	38 500 kg (85,000 lb.)	18.0 m/min. (61 ft./min.)	Hydraulic – Ripper	1238 kg (2,730 lb.)
H85 <sup>†</sup>	38 500 kg (85,000 lb.)	25.0 m/min. (82 ft./min.)	Hydraulic – Hi-Performance	1238 kg (2,730 lb.)
Carco H110B <sup>†</sup>	49 900 kg (110,000 lb.)	12.0 m/min. (41 ft./min.)	Hydraulic – Ripper	1791 kg (3,950 lb.)
H110B <sup>†</sup>	49 900 kg (110,000 lb.)	17.0 m/min. (55 ft./min.)	Hydraulic – Hi-Performance	1791 kg (3,950 lb.)
H110B*	49 900 kg (110,000 lb.)	37.0 m/min. (110 ft./min.)	Hydrostatic	1791 kg (3,950 lb.)
H140*	63 503 kg (140,000 lb.)	27.0 m/min. (90 ft./min.)	Hydrostatic	1750 kg (3,860 lb.)
<b>950K</b>				
H110B <sup>†</sup>	49 895 kg (110,000 lb.)	16.0 m/min. (53 ft./min.)	Hydraulic – Ripper	1791 kg (3,950 lb.)
H140 <sup>†</sup>	63 503 kg (140,000 lb.)	13.0 m/min. (41 ft./min.)	Hydraulic – Ripper	1750 kg (3,860 lb.)
<b>1050K</b>				
H110B <sup>†</sup>	49 895 kg (110,000 lb.)	22.0 m/min. (71 ft./min.)	Hydraulic – Ripper	1791 kg (3,950 lb.)
H140 <sup>†</sup>	63 503 kg (140,000 lb.)	17.0 m/min. (55 ft./min.)	Hydraulic – Ripper	1750 kg (3,860 lb.)

\*Hydrostatic – Winch powered by a dedicated closed-loop hydrostatic circuit (winch kit includes hydrostatic pump and associated plumbing).

<sup>†</sup>Hydraulic – Ripper – Winch powered by machine's open-loop implement hydraulic system and requires John Deere ripper-control system.

<sup>‡</sup>Hydraulic – Hi-Performance – Winch powered by machine's open-loop implement hydraulic system and optimized for John Deere winch-ready conversion.

Contact your local dealer for more information.

[Back to Table of Contents](#)

# BUCKETS

## BACKHOE



### FEATURES

#### Heavy-duty front loader for backhoe loaders:

- Bucket is designed for material handling including load-and-carry, grading, and back-dragging applications.
- Optimized back-sheet design and formed construction help increase bucket fill for greater productivity.
- Standard bolt-on cutting edge and welded skid shoes enhance wear protection.
- Bucket is available in pin-on and coupler configurations.

#### Heavy-duty long-lip front loader for backhoe loaders:

- Bucket is designed for material handling including load-and-carry, grading, and back-dragging applications.
- Longer lip increases bucket capacity.
- Optimized back-sheet design and formed construction help increase bucket fill for greater productivity.
- Standard bolt-on cutting edge and welded skid shoes enhance wear protection.
- Bucket is available in pin-on and coupler configurations.

#### Multipurpose front loader for backhoe loaders:

- Bucket is designed for loading, material-handling, grading, back-dragging, clamping, and grappling applications.
- Additional third bolt-on cutting edge improves durability and wear life.
- Design features curved side sheets to limit spill and increase capacity.
- Bucket is available in pin-on and coupler configurations.

#### Standard-duty rear backhoe for backhoe loaders:

- Bucket includes standard profile teeth and 23-Series adapters that accept any 23-Series tooth to match ground condition and application.
- Design features bushings in each pivot joint for serviceability.
- Bucket is designed for general digging and truck loading of loose soil and gravel.
- Multi-radius back-sheet design optimizes digging performance and material flow for high bucket fill on each pass, with tapered side sheets that ease digging and unloading.

#### Heavy-duty rear backhoe for backhoe loaders:

- Bucket includes Fanggs™ profile teeth and TK225-Series adapters that accept any TK225-Series tooth to match ground condition and application.
- Designed for difficult digging conditions in rocky soil where material is hard and compacted, this is the optimal bucket for underground trenching and backfilling.
- Multi-radius back-sheet design optimizes digging performance and material flow for high bucket fill on each pass, with tapered side sheets that ease digging and unloading.

Contact your local dealer for more information.

[Back to Table of Contents](#)



# BUCKETS

BACKHOE (continued)



## FEATURES

### Severe-duty rear backhoe for backhoe loaders:

- Bucket includes Fanggs profile teeth and TK225-Series adapters that accept any TK225-Series tooth to match ground condition and application.
- Construction includes horizontal strips along the back sheet and side sheets for wear protection.
- Designed for tough digging in rocky soil where material is hard and compacted, this is the optimal bucket for underground trenching and backfilling.
- Multi-radius back-sheet design optimizes digging performance and material flow for high bucket fill on each pass, with tapered side sheets that ease digging and unloading.

### Top-hook rear backhoe for backhoe loaders:

- Bucket includes Fanggs profile teeth and TK225-Series adapters that accept any TK225-Series tooth to match ground condition and application.
- Design is compatible with John Deere top-hook, C&P top-hook, and pre-XLS Wain-Roy couplers.
- Designed for difficult digging in rocky soil where material is hard and compacted, this is the optimal bucket for underground trenching and backfilling.
- Construction includes vertical strips along the back sheet for wear protection.
- Multi-radius back-sheet design optimizes digging performance and material flow for high bucket fill on each pass, with tapered side sheets that ease digging and unloading.

Contact your local dealer for more information.

[Back to Table of Contents](#)

# BUCKETS

## EXCAVATORS



### FEATURES AND SPECIFICATIONS

#### Heavy-duty buckets:

- Buckets are equipped with Fanggs™ profile teeth and TK-Series adapters compatible with TK-Series tooth options to match ground condition and application.
- Buckets include wear strips along the back sheet for extra protection.
- Multi-radius back sheet optimizes bucket filling and dumping.
- Tapered design enables improved bucket clearance, to minimize digging resistance and wear.

#### 130G–470 P-Tier Excavator specific:

- Single-piece header improves load distribution across the bucket and enhances durability.
- Abrasion-resistant wear material in cutting edge, side cutters, and bottom corners reduces wear and extends bucket life.
- Buckets are predrilled for optional side cutters or shrouds.

#### Severe-duty buckets:

- Design provides the same benefits as heavy-duty buckets with increased wear protection to improve durability in difficult conditions.
- Buckets are equipped with larger TK-Series severe-duty teeth, for better performance in harsh conditions.
- Buckets come with preinstalled bolt-on side cutters.

#### Ditch-cleanup buckets for 75G and 85G Excavators:

- Buckets are similar in shape and capacity to heavy-duty buckets, but feature a bolt-on cutting edge instead of teeth.
- Design does not include wear strips along the back of the bucket.
- These buckets are ideal for digging light materials or for preparing or maintaining a grade.

75G/85G/130G/135G/160G LC/200G/210G LC/245G LC/250G LC/300G LC/345G LC/350 P-Tier/380 P-Tier/470 P-Tier Excavators

Bucket Type	Rated Capacity	Width	Weight	Bucket Pin to Cutting-Edge Radius	Bucket Pin to Tooth-Tip Radius	Number of Teeth
Heavy Duty	0.25 m <sup>3</sup> (0.33 cu. yd.)	610 mm (24 in.)	212 kg (466 lb.)	880 mm (34.6 in.)	943 mm (37.2 in.)	5
	0.28 m <sup>3</sup> (0.37 cu. yd.)	762 mm (30 in.)	225 kg (495 lb.)	880 mm (34.6 in.)	943 mm (37.2 in.)	5
	0.35 m <sup>3</sup> (0.46 cu. yd.)	915 mm (36 in.)	255 kg (561 lb.)	880 mm (34.6 in.)	943 mm (37.2 in.)	6
Ditch Cleanup	0.35 m <sup>3</sup> (0.46 cu. yd.)	915 mm (36 in.)	233 kg (513 lb.)	908 mm (35.7 in.)	N/A	N/A

Contact your local dealer for more information.

[Back to Table of Contents](#)

# BUCKETS

## UTILITY LOADERS



### FEATURES AND SPECIFICATIONS

#### Enhanced performance for utility loaders:

- Bucket is available in pin-on, standard coupler, or Hi-Vis coupler configurations.
- Integrated curved side cutter improves material retention and machine-loading time.
- Integrated bucket-spill deflector protects linkage from material spillage.
- Standard equipped with bolt-on cutting edges and integrated skid shoes for wear protection.

#### Light-material for utility loaders:

- Bucket is available in standard or Hi-Vis coupler configurations in 4.00-, 4.50-, or 5.25-cubic-yard capacities.
- Bucket is designed specifically for high-productivity loading of lower-density material such as in ag material handling.
- Height over loader is the same as for pin-on buckets.

Contact your local dealer for more information.

[Back to Table of Contents](#)

Key: High-Lift = HL, High-Lift Plus = HLP, Tool Carrier = TC

Bucket Type	Coupler Interface Series	Rated Capacity	Width	Weight	P-Tier Models
Enhanced Performance	N/A	1.9 m <sup>3</sup> (2.5 cu. yd)	2540 mm (100 in.)	960 kg (2,116 lb.)	444, HL
		2.1 m <sup>3</sup> (2.75 cu. yd)	2540 mm (100 in.)	1033 kg (2,277 lb.)	524, HL, HLP; 544, HL, HLP
		2.3 m <sup>3</sup> (3.0 cu. yd)	2540 mm (100 in.)	1072 kg (2,363 lb.)	524, HL, HLP; 544, HL, HLP
		2.5 m <sup>3</sup> (3.25 cu. yd)	2692 mm (106 in.)	1109 kg (2,444 lb.)	524, HL; 544, HL, HLP
		2.7 m <sup>3</sup> (3.5 cu. yd)	2692 mm (106 in.)	1172 kg (2,583 lb.)	624, HL, HLP
		2.9 m <sup>3</sup> (3.75 cu. yd)	2692 mm (106 in.)	1215 kg (2,678 lb.)	624, HL, HLP
		3.2 m <sup>3</sup> (4.25 cu. yd)	3048 mm (120 in.)	1795 kg (3,956 lb.)	644, HL; 724, HL; 644 X-Tier
		3.4 m <sup>3</sup> (4.5 cu. yd)	3048 mm (120 in.)	1831 kg (4,036 lb.)	644, HL; 724, HL; 644 X-Tier
		3.6 m <sup>3</sup> (4.75 cu. yd)	3048 mm (120 in.)	1870 kg (4,121 lb.)	644, HL; 724, HL; 644 X-Tier
		3.8 m <sup>3</sup> (5.0 cu. yd)	3048 mm (120 in.)	1910 kg (4,210 lb.)	724, HL
Enhanced Performance	JRB 416 Series	1.9 m <sup>3</sup> (2.5 cu. yd)	2540 mm (100 in.)	941 kg (2,074 lb.)	444, HL; 524, HL, HLP, TC; 544, HL, HLP; 624, HL, HLP, TC
		2.1 m <sup>3</sup> (2.75 cu. yd)	2540 mm (100 in.)	1000 kg (2,204 lb.)	444, HL; 524, HL, HLP, TC; 544, HL, HLP; 624, HL, HLP, TC
		2.3 m <sup>3</sup> (3.0 cu. yd)	2692 mm (106 in.)	1036 kg (2,283 lb.)	444; 524, HL, TC; 544, HL, HLP; 624, HL, HLP, TC
		2.5 m <sup>3</sup> (3.25 cu. yd)	2692 mm (106 in.)	1100 kg (2,424 lb.)	524, TC; 544, HL; 624, HL, HLP, TC
		2.7 m <sup>3</sup> (3.5 cu. yd)	2692 mm (106 in.)	1105 kg (2,435 lb.)	544; 624, HL, TC
		2.9 m <sup>3</sup> (3.75 cu. yd)	2692 mm (106 in.)	1143 kg (2,519 lb.)	624, TC
	Standard Coupler / JRB 418 Series	3.1 m <sup>3</sup> (4.0 cu. yd)	3048 mm (120 in.)	1691 kg (3,727 lb.)	644, HL; 724, HL; 644 X-Tier
		3.2 m <sup>3</sup> (4.25 cu. yd)	3048 mm (120 in.)	1710 kg (3,769 lb.)	644, HL; 724, HL; 644 X-Tier
		3.4 m <sup>3</sup> (4.5 cu. yd)	3048 mm (120 in.)	1790 kg (3,945 lb.)	644, HL; 724, HL; 644 X-Tier
		3.6 m <sup>3</sup> (4.75 cu. yd)	3048 mm (120 in.)	1825 kg (4,104 lb.)	644, HL; 724, HL; 644 X-Tier
Light Material	JRB 416 Series	3.8 m <sup>3</sup> (5.0 cu. yd)	3048 mm (120 in.)	1862 kg (4,104 lb.)	724, HL
		3.1 m <sup>3</sup> (4.0 cu. yd)	2896 mm (114 in.)	1233 kg (2,718 lb.)	444, HL; 524, HL, HLP, TC; 544, HL, HLP; 624, HL, HLP, TC
Enhanced Performance	ISO Coupler	3.4 m <sup>3</sup> (4.5 cu. yd)	2896 mm (114 in.)	1315 kg (2,898 lb.)	444, HL; 524, HL, HLP, TC; 544, HL, HLP; 624, HL, HLP, TC
		4.0 m <sup>3</sup> (5.25 cu. yd)	3048 mm (120 in.)	1400 kg (3,086 lb.)	544, HL, HLP; 624, HL, HLP, TC
		1.9 m <sup>3</sup> (2.5 cu. yd)	2540 mm (100 in.)	945 kg (2,082 lb.)	444, HL; 524, HL, HLP, TC; 544, HL, HLP; 624, HL, HLP, TC
		2.1 m <sup>3</sup> (2.75 cu. yd)	2540 mm (100 in.)	1000 kg (2,204 lb.)	444, HL; 524, HL, HLP, TC; 544, HL, HLP; 624, HL, HLP, TC
		2.3 m <sup>3</sup> (3.0 cu. yd)	2692 mm (106 in.)	1036 kg (2,283 lb.)	444; 524, HL, TC; 544, HL, HLP; 624, HL, HLP, TC
		2.5 m <sup>3</sup> (3.25 cu. yd)	2692 mm (106 in.)	1082 kg (2,385 lb.)	524, TC; 544, HL; 624, HL, HLP, TC
		2.7 m <sup>3</sup> (3.5 cu. yd)	2692 mm (106 in.)	1104 kg (2,433 lb.)	544; 624, HL, TC
		2.9 m <sup>3</sup> (3.75 cu. yd)	2692 mm (106 in.)	1142 kg (2,517 lb.)	624, TC
		3.1 m <sup>3</sup> (4.0 cu. yd)	3048 mm (120 in.)	1637 kg (3,608 lb.)	644, HL; 724, HL; 644 X-Tier; 644 G-Tier
		3.2 m <sup>3</sup> (4.25 cu. yd)	3048 mm (120 in.)	1695 kg (3,736 lb.)	644, HL; 724, HL; 644 X-Tier; 644 G-Tier
Light Material	ISO Coupler	3.4 m <sup>3</sup> (4.5 cu. yd)	3048 mm (120 in.)	1735 kg (3,824 lb.)	644, HL; 724, HL; 644 X-Tier
		3.6 m <sup>3</sup> (4.75 cu. yd)	3048 mm (120 in.)	1770 kg (3,901 lb.)	644, HL; 724, HL; 644 X-Tier
		3.8 m <sup>3</sup> (5.0 cu. yd)	3048 mm (120 in.)	1808 kg (3,985 lb.)	724, HL
		3.1 m <sup>3</sup> (4.0 cu. yd)	2896 mm (114 in.)	1281 kg (2,823 lb.)	444, HL; 524, HL, HLP, TC; 544, HL, HLP; 624, HL, HLP, TC
		3.4 m <sup>3</sup> (4.5 cu. yd)	2896 mm (114 in.)	1342 kg (2,958 lb.)	444, HL; 524, HL, HLP, TC; 544, HL, HLP; 624, HL, HLP, TC
		4.0 m <sup>3</sup> (5.25 cu. yd)	3048 mm (120 in.)	1426 kg (3,143 lb.)	544, HL, HLP; 624, HL, HLP, TC

# BUCKETS

## PRODUCTION LOADERS

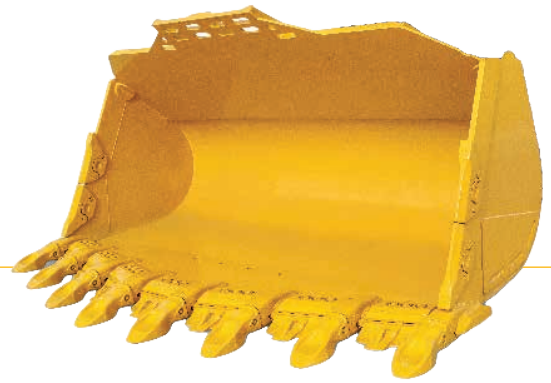

### FEATURES

#### Enhanced performance for 744 P-Tier and 824 P-Tier Loaders:

- Bucket is available in standard coupler or pin-on configurations in 5.50- to 6.25-cubic-yard capacities.
- Choose unlined or lined for high-wear applications.
- Replaceable bushed joints improve bore life.
- Bolt-on lower-side cutters provide additional protection.

#### Enhanced performance for 844 P-Tier Loader:

- Bucket is available in pin-on configurations in 6.25- to 7.50-cubic-yard capacities.
- Choose unlined or lined for high-wear applications.
- Replaceable bushed joints improve bore life.
- Bolt-on lower-side cutters provide additional protection.

#### General purpose for 944K Loader:

- Bucket is available in pin-on configuration in 10.00-cubic-yard capacity.
- Bolt-on lower-side cutters provide additional protection.
- Replaceable bushed joints improve bore life.

#### Material handler for 744 P-Tier and 824 P-Tier Loaders:

- Bucket is available in standard pin-on configuration in 6.75-cubic-yard capacity.

#### Material handler for 844 P-Tier Loader:

- Bucket is available in standard pin-on configuration in 8.00-cubic-yard capacity.

#### Material handler for 904 P-Tier Loader:

- Bucket is available in either 9.30- or 9.80-cubic-yard capacities.
- Loading a typical 24-ton over-the-road truck in two passes, the third pass is eliminated.
- Bucket can accommodate 12 tons of lower-density non-heaping material.
- Bolt-on cutting edges are standard.

#### Granite for 944K Loader:

- Bucket is designed for loading material at the pit face in the highest-abrasion and -impact applications.
- Bucket is standard equipped with either penetration or heavy-abrasion teeth and TK550-Series adapters that accept any TK550-Series tooth to match ground condition and application.
- Designed for optimal material penetration and loading, the spade-nose-base cutting edge is predrilled for bolt-on double-bevel or half-arrow cutting edges with cover plates.
- Bucket includes abrasion-resistant liner, side sheet, and bottom plates for high-wear performance in the toughest applications.
- Integrated spill deflector protects bucket linkage from material flowing over the back sheet.

#### Rock for 944K Loader:

- Bucket is available in 9.00- and 10.00-cubic-yard capacities in either cutting-edge or teeth configurations.

Contact your local dealer for more information.

[Back to Table of Contents](#)

# BUCKETS

## PRODUCTION LOADERS (continued)

### SPECIFICATIONS

Bucket Type	Coupler Interface Series	Rated Capacity	Width	Weight	P-Tier Models
Enhanced Performance	Standard Coupler / JRB 420 Series	3.8 m <sup>3</sup> (5.0 cu. yd.)	3280 mm (129 in.)	2441 kg (5,382 lb.)	744 and 824
		4.0 m <sup>3</sup> (5.25 cu. yd.)	3280 mm (129 in.)	2592 kg (5,714 lb.)	744 and 824
		4.4 m <sup>3</sup> (5.75 cu. yd.)	3280 mm (129 in.)	2866 kg (6,318 lb.)	824
		4.6 m <sup>3</sup> (6.0 cu. yd.)	3280 mm (129 in.)	2913 kg (6,422 lb.)	824
Enhanced Performance	Pin On	4.0 m <sup>3</sup> (5.25 cu. yd.)	3280 mm (129 in.)	2592 kg (5,714 lb.)	744 and 824
		4.2 m <sup>3</sup> (5.50 cu. yd.)	3280 mm (129 in.)	2866 kg (6,318 lb.)	744 and 824
		4.6 m <sup>3</sup> (6.0 cu. yd.)	3280 mm (129 in.)	2730 kg (6,019 lb.)	824
		4.8 m <sup>3</sup> (6.25 cu. yd.)	3280 mm (129 in.)	3009 kg (6,634 lb.)	824
		5.6 m <sup>3</sup> (7.25 cu. yd.)	3460 mm (136 in.)	3515 kg (7,749 lb.)	844
		5.7 m <sup>3</sup> (7.50 cu. yd.)	3460 mm (136 in.)	3763 kg (8,296 lb.)	844
Material Handling	Pin On	4.5 m <sup>3</sup> (5.85 cu. yd.)	3280 mm (129 in.)	2913 kg (6,422 lb.)	744 and 824
		5.1 m <sup>3</sup> (6.75 cu. yd.)	3280 mm (129 in.)	3073 kg (6,775 lb.)	824
		6.1 m <sup>3</sup> (8.0 cu. yd.)	3280 mm (129 in.)	3835 kg (8,455 lb.)	844
		7.1 m <sup>3</sup> (9.3 cu. yd.)	3650 mm (144 in.)	4096 kg (9,030 lb.)	904
		7.5 m <sup>3</sup> (9.8 cu. yd.)	3650 mm (144 in.)	4218 kg (9,300 lb.)	904
Spade Nose	Pin On	4.8 m <sup>3</sup> (6.25 cu. yd.)	3490 mm (137 in.)	4217 kg (9,297 lb.)	844
		6.9 m <sup>3</sup> (9.0 cu. yd.)	4060 mm (156 in.)	6144 kg (13,545 lb.)	944
		7.7 m <sup>3</sup> (10.0 cu. yd.)	4060 mm (156 in.)	6482 kg (14,291 lb.)	944
Heavy-Duty Granite	Pin On	6.5 m <sup>3</sup> (8.5 cu. yd.)	4060 mm (156 in.)	7416 kg (16,349 lb.)	944

Contact your local dealer for more information.

[Back to Table of Contents](#)



# HYDRAULIC HAMMERS

HH80C | HH90 | HH115 | HH125 | HH135 | HH145



## FEATURES

- These hammers are the perfect replacement for cranes equipped with wrecking balls, enabling much more controlled and efficient primary demolition. They can also aid in smashing ground rubble and separating rebar from concrete.
- Use these hammers to break a narrow trench for laying pipe, cables, or drainage. Or use them to break down blasted rock that's too big for a feeder or crusher. In areas where blasting isn't allowed, they can break away rock to be removed by truck.
- Capable of breaking up concrete, hard ground, and small boulders, these hammers are ideal for quarry, demolition, and site preparation.
- Stroke-selection system on the HH145 switches between short-stroke high-impact rate or long-stroke high-impact energy to best match the application.
- Simple tool-retaining system and lower-tool bushing can easily be replaced in the field, saving a trip to the dealership.
- Single-body design on the HH90 enables fast, easy service requiring fewer parts and no special tools. Single lower-tool bushing eliminates the need for upper- and lower-tool bushings. Protected swivel-hose couplings allow free movement, reducing wear of hoses and fittings.
- Membrane-type accumulator design eliminates nitrogen leaks and oil-pressure peaks, delivering constant maximum-impact power without the need to recharge on the job.
- On the HH115, HH125, HH135, and HH145, a restrictor valve protects against damage and premature failure from system overload, while idle-blow protection prevents idle strokes, helping extend hammer life. Standard Auto-Lube system increases service life for wear parts while reducing downtime and grease waste.
- Cost-effectively prepare materials for landfills while meeting strict environmental regulations.
- These hydraulic hammers are optimized to work with John Deere 75G–380 P-Tier Excavators. They're also compatible with many competitive models.

[Learn more about Hydraulic Hammers](#)

[Back to Table of Contents](#)

## SPECIFICATIONS

Model	HH80C	HH90	HH115	HH125	HH135	HH145
Impact Energy Class	1017 J (750 ft.-lb.)	1627 J (1,200 ft.-lb.)	3390 J (2,500 ft.-lb.)	4745 J (3,500 ft.-lb.)	6779 J (5,000 ft.-lb.)	10 847 J (8,000 ft.-lb.)
Hammer Weight	320 kg (695 lb.)	410 kg (910 lb.)	890 kg (1,960 lb.)	1130 kg (2,490 lb.)	1410 kg (3,110 lb.)	1970 kg (4,340 lb.)
Operating Weight	400 kg (870 lb.)	500 kg (1,100 lb.)	1,100 kg (2,430 lb.)	1360 kg (3,000 lb.)	1670 kg (3,680 lb.)	2350 kg (5,180 lb.)
Overall Height						
With Moil-Point Tool	1449 mm (57 in.)	1669 mm (66 in.)	—	—	—	—
Without Tool	1032 mm (41 in.)	1217 mm (48 in.)	1577 mm (62 in.)	1810 mm (71.25 in.)	1862 mm (73.3 in.)	2118 mm (83.4 in.)
Overall Width						
Mounting Bracket	380 mm (15 in.)	400 mm (16 in.)	510 mm (20 in.)	510 mm (20 in.)	510 mm (20 in.)	540 mm (21 in.)
Main Body	257 mm (11 in.)	280 mm (11 in.)	570 mm (22 in.)	630 mm (25 in.)	630 mm (25 in.)	680 mm (27 in.)
Attachment Depth (no bit or mount)	520 mm (20 in.)	520 mm (20 in.)	570 mm (22 in.)	570 mm (22 in.)	570 mm (22 in.)	620 mm (24 in.)
Impact Rate	700–2,600 blows/min.	500–1,700 blows/min.	540–920 blows/min.	430–790 blows/min.	450–750 blows/min.	370–630 blows/ min. long stroke / 460–740 blows/ min. short stroke
Noise Level						
Measured Sound Power, LWA	120 dB	123 dB	123 dB	121 dB	120 dB	124 dB
Guaranteed Sound Power, LWA	124 dB	127 dB	127 dB	125 dB	124 dB	128 dB
Tool Diameter	80 mm (3.15 in.)	90 mm (3.54 in.)	115 mm (4.52 in.)	125 mm (4.92 in.)	135 mm (5.31 in.)	142 mm (5.59 in.)
<b>Hydraulics</b>						
Hydraulic Flow						
Minimum	40 L/min. (10.6 gpm)	50 L/min. (13 gpm)	90 L/min. (24 gpm)	120 L/min. (32 gpm)	140 L/min. (37 gpm)	160 L/min. (42.3 gpm)
Maximum	120 L/min. (31.7 gpm)	150 L/min. (40 gpm)	130 L/min. (34 gpm)	180 L/min. (483 gpm)	200 L/min. (53 gpm)	250 L/min. (66 gpm)
Operating Pressure	4–14 MPa (1,305–2,030 psi)	10–14 MPa (1,450–2,030 psi)	13.5–14.5 MPa (1,960–2,105 psi)	14–16 MPa (2,030–2,320 psi)	13.5–14.5 MPa (1,960–2,105 psi)	15–16 MPa (2,175–2,320 psi)
Maximum Machine Auxiliary Relief	22 MPa (3,191 psi)	22 MPa (3,191 psi)	22 MPa (3,191 psi)	23 MPa (3,335 psi)	22 MPa (3,190 psi)	24 MPa (3,480 psi)
Maximum Back Pressure	2 MPa (290 psi)	2 MPa (290 psi)	1 MPa (145 psi)	1 MPa (145 psi)	1 MPa (145 psi)	1 MPa (145 psi)
Line Connection						
Pressure	0.75-in. Female BSPP	1-in. Female BSPP	1-in. SAE Code 62	1.25-in. SAE Code 62	1.25-in. SAE Code 62	1.25-in. SAE Code 62
Return	0.75-in. Female BSPP	1-in. Female BSPP	1-in. SAE Code 62	1.25-in. SAE Code 62	1.25-in. SAE Code 62	1.25-in. SAE Code 62
<b>Options</b>						
Mounting System (bracket and hoses)	Option (machine equipped with disconnects)	Option (machine equipped with selector valve)	Option	Option (not on the 200G and 245G LC)	Option	Option
Tools						
Moil Point	Standard	Standard	Option / Field Kit / Service Part	Option / Field Kit / Service Part	Option / Field Kit / Service Part	Option / Field Kit / Service Part
Long	N/A	N/A	N/A	N/A	Option / Field Kit / Service Part	N/A
Chisel Point	Service Part	Service Part	Option / Field Kit / Service Part	Option / Field Kit / Service Part	Option / Field Kit / Service Part	Option / Field Kit / Service Part
Long	N/A	N/A	N/A	N/A	Option / Field Kit / Service Part	N/A
Limestone	N/A	N/A	N/A	N/A	Option / Field Kit / Service Part	Option / Field Kit / Service Part
Hard Rock	N/A	N/A	N/A	N/A	Option / Field Kit / Service Part	Option / Field Kit / Service Part
Spade						
Parallel to Boom	Service Part	Service Part	N/A	N/A	N/A	N/A
Perpendicular to Boom	Service Part	Service Part	N/A	N/A	N/A	N/A
Compacting Plate	Service Part	Service Part	N/A	N/A	N/A	N/A
Blunt Point	N/A	N/A	Option / Field Kit / Service Part	Option / Field Kit / Service Part	Option / Field Kit / Service Part	Option / Field Kit / Service Part
Long	N/A	N/A	N/A	N/A	Option / Field Kit / Service Part	N/A
Super	N/A	N/A	N/A	N/A	Option / Field Kit / Service Part	Option / Field Kit / Service Part
Pyramid Point	N/A	N/A	Option / Field Kit / Service Part	Option / Field Kit / Service Part	Option / Field Kit / Service Part	Option / Field Kit / Service Part
<b>Vehicle Compatibility</b>						
Hydraulic Connection	0.5-in. Flat-Face Disconnect	G3/4 JIS	JIS or ORFS	JIS or ORFS	JIS or ORFS	JIS or ORFS
Excavators	N/A	75G and 85G	130G, 135G, and 160G LC (with auxiliary high-flow hydraulics)	160G LC, 200G, 210G/210G LC, and 245G LC (with auxiliary high-flow hydraulics)	250G LC and 300G LC (with auxiliary high-flow hydraulics)	300G LC, 345G LC, 350 P-Tier, and 380 P-Tier (with auxiliary high-flow hydraulics)
Backhoes	310L, 310SL, 310SL HL, and 410L	N/A	N/A	N/A	N/A	N/A
Allowed Carrier Weight	4.6–9 ton (10,150–19,850 lb.)	6.6–10 ton (14,600–23,400 lb.)	12–20 ton (26,500–44,100 lb.)	16–26 ton (35,300–57,300 lb.)	21–32 ton (46,300–70,560 lb.)	26–42 ton (57,300–92,600 lb.)

Requires additional cab guarding for operation.

# ROTARY CUTTER

RE50



## FEATURES AND SPECIFICATIONS

- The RE50 rotary cutter uses three swinging blades mounted to a blade carrier to maximize cutting performance.
- The RE50 is able to fell and cut material up to six inches in diameter. Directionally beveled blades push material into the head of the cutter, creating finer debris for easier recycling.
- Blades are reversible, so when the leading edge wears, the blades can be unbolted and flipped over to expose a fresh cutting edge.
- Heavy-duty hinged debris shield retracts when the head is engaged with trees and brush, exposing the blades and allowing for aggressive cuts.
- Automatic hydraulic braking quickly stops blade rotation after the machine is turned off, making it faster for operators to exit the cab.
- This rotary cutter is optimized to work with John Deere 75G and 85G Excavators. They're also compatible with many competitive models.

Model	RE50
<b>Width</b>	
Overall	1590 mm (63 in.)
Cutting	1270 mm (50 in.)
<b>Height</b>	600 mm (24 in.)
<b>Length</b>	1450 mm (57 in.)
<b>Weight</b> (not including mounting bracket)	480 kg (1,050 lb.)
<b>Minimum Cutting Height</b>	57 mm (2.25 in.)
<b>Cutting Capacity</b> (maximum tree diameter)	127 mm (5 in.)
<b>Approved Carrier Weight Range</b>	5000–8000 kg (11,023–17,636 lb.)
<b>Number of Blades</b>	3
<b>Hydraulic Flow</b>	
Minimum	64 L/min. (17 gpm) / [83 L/min. (22 gpm) high flow]
Maximum	83 L/min. (22 gpm) / [129 L/min. (34 gpm) high flow]
<b>Maximum Operating Pressure</b>	24 000 kPa (3,500 psi)
<b>Vehicle Compatibility</b>	75G and 85G
<i>Requires additional cab guarding for operation.</i>	

[Learn more about Rotary Cutters](#)

[Back to Table of Contents](#)





# THUMBS

BACKHOES | EXCAVATORS

## FEATURES

### For 310L EP/310L/310SL/310SL HL/410L Backhoe Loaders:

- 37- and 42-inch thumb-tine lengths mesh securely with machine coupler and bucket configurations.
- Tine-and-bucket combination meshes with 24-inch buckets having five teeth.
- Optimized design profile enables operation of the backhoe when the thumb is not in use.
- Serrated-tine design grips even the most difficult and irregularly shaped material.
- Models are also compatible with J- and K-Series Backhoe Loaders.

### For 130G/135G/160G LC/200G/210G LC/245G LC/250G LC/300G LC/345G LC/350 P-Tier/380 P-Tier/470 P-Tier Excavators:

- Direct style provides rotation of up to 140 degrees.
- Progressive style allows full thumb rotation through the bucket's range of motion.
- Optimized design profile enables operation of the excavator when the thumb is not in use.
- Lock-back bracket retains the thumb when not in use to prevent cylinder drift.
- Serrated-tine design grips even the most difficult and irregularly shaped material.

Contact your local dealer for more information.

[Back to Table of Contents](#)

# COUPLERS

## BACKHOES



### FEATURES

#### Front loader hydraulic for 210L EP/210L Tractor Loaders and 310L/310L EP/310SL/310SL HL/410L Backhoes:

- Coupler enables attachment of G, J, K, and L-Series loader-coupler buckets.
- Attachment changeover is hydraulically controlled from the cab.
- High-strength steel hook pins deliver reliable durability and wear resistance.
- Visibility is optimized at ground level for coupling and to the fork tips at truck-loading height.

#### Rear backhoe standard John Deere for 310L EP/310L Backhoes:

- Coupler enables attachment of 310E/G/J/K/K EP/L/L EP buckets and attachments.
- Manual changeover of John Deere attachments is quick and easy.
- High-strength steel hooks deliver reliable durability and wear resistance.

#### Rear backhoe standard John Deere for 310SL/310SL HL/410L Backhoes:

- Coupler enables attachment of 310SE/SG/SJ/SK/SL and 410E/G/J/K/L buckets and attachments.
- Manual changeover of John Deere attachments is quick and easy.
- High-strength steel hooks deliver reliable durability and wear resistance.

#### Rear backhoe multi-brand for 310L EP/310L Backhoes:

- Coupler allows customers with mixed fleets to easily switch between John Deere and some competitive attachments.
- Coupler enables attachment of Deere C/D/E/G/J-Series buckets as well as Case K- and L-Series and CAT® B- and C-Series buckets.

#### Rear backhoe top hook for 310L EP/310L/310SL/410L Backhoes:

- Coupler allows for fast, single-pin attachment changes, increasing versatility.
- Design is compatible with John Deere, pre-XLS Wain-Roy, and C&P top-hook attachments.
- Coupler and bucket design provides comparable tip radius of pin-on buckets for minimal impact on breakout forces.

#### Rear backhoe hydraulic for 310SL/310SL HL/410L Backhoes:

- Coupler enables attachment of 310SE/SG/SJ/SK/SL and 410E/G/J/K/L buckets and attachments.
- Attachment changeover is hydraulically controlled from the cab.
- Design features a hydraulic and mechanical coupler-locking system.

#### Rear backhoe spring-type for 310SL/310SL HL/410L Backhoes:

- Coupler enables attachment of 310SE/SG/SJ/SK/SL and 410E/G/J/K/L buckets and attachments.
- Mechanical connection of coupler is automatic without the need to exit the cab.\*

\*Detachment requires the operator to exit the cab.

Contact your local dealer for more information.

[Back to Table of Contents](#)

# COUPLERS

## LOADERS



### FEATURES

#### Standard for 444 P-Tier/524 P-Tier/544 P-Tier/544 G-Tier/624 P-Tier Loaders:

- Coupler is compatible with John Deere 444–624 standard coupler attachments as well as JRB 416 interface attachments.
- Attachment changeover is hydraulically controlled from the cab.
- Locked/unlocked visual indicators let the operator easily confirm cylinder-pin location.
- Hydraulic-check valve prevents loss of hydraulic pressure.
- High cylinder unlocking/locking force eases connection and detachment.

#### Standard for 644 G-Tier/644 P-Tier/644 X-Tier/724 P-Tier Loaders:

- Coupler is compatible with John Deere 644–724 standard coupler attachments as well as JRB 418 interface attachments.
- Attachment changeover is hydraulically controlled from the cab.
- Locked/unlocked visual indicators let the operator easily confirm cylinder-pin location.
- Hydraulic-check valve prevents loss of hydraulic pressure.
- High cylinder unlocking/locking force eases connection and detachment.

#### Hi-Vis for 444 P-Tier/524 P-Tier/544 G-Tier/544 P-Tier/624 P-Tier Loaders:

- Coupler is compatible with John Deere 444–624 Hi-Vis coupler attachments as well as ISO 23727 attachments.
- Attachment changeover is hydraulically controlled from the cab.
- Locked/unlocked visual indicators let the operator easily confirm cylinder-pin location.
- Hydraulic-check valve prevents loss of hydraulic pressure.
- High cylinder unlocking/locking force eases connection and detachment.

#### Hi-Vis for 644 G-Tier/644 P-Tier/644 X-Tier/724 P-Tier Loaders:

- Coupler is compatible with John Deere 644–724 standard coupler attachments as well as ISO 23727 interface attachments.
- Attachment changeover is hydraulically controlled from the cab.
- Locked/unlocked visual indicators let the operator easily confirm cylinder-pin location.
- Hydraulic-check valve prevents loss of hydraulic pressure.
- High cylinder unlocking/locking force eases connection and detachment.

#### Standard for 744 P-Tier and 824 P-Tier Loaders:

- Coupler is compatible with John Deere 744 and 824 standard coupler buckets and construction utility forks as well as JRB 420 interface attachments.
- Attachment changeover is hydraulically controlled from the cab.
- Locked/unlocked visual indicators let the operator easily confirm cylinder-pin location.
- Hydraulic-check valve prevents loss of hydraulic pressure.
- High cylinder unlocking/locking force eases connection and detachment.

Contact your local dealer for more information.

[Back to Table of Contents](#)

# COUPLERS

## EXCAVATORS



### FEATURES

- A high-performance quick coupler based on absolute flexibility and uncompromising utility.
- The lightest, lowest, innovative fully cast body shell capable of withstanding all working environments.
- Heat-treated high-grade steel designed to guarantee its strength and help eliminate weak points to enhance durability in high-stress operations.
- New low-profile design delivering a shorter pin-to-point measurement, which delivers maximum breakout force for greater productivity and efficiency.

Key		75G	85G	130G	135G	160G LC		180G LC, 210G LC, 245G LC	250G LC, 290G LC, 300G LC, 345G LC		350 P-tier	380 P-tier
Coupler Weight		96 kg (211 lb.)		185 kg (407 lb.)		268 kg (590 lb.)		329 kg (724 lb.)	438 kg (964 lb.)		584 kg (1,285 lb.)	
Minimum Attachment Width	AW	169 mm (6.66 in.)		221 mm (8.70 in.)		277 mm (10.91 in.)		307 mm (12.08 in.)	326 mm (12.84 in.)		345 mm (13.59 in.)	
Pin Diameter	D	50 mm (1.97 in.)	60 mm (2.36 in.)	60 mm (2.36 in.)	65 mm (2.56 in.)	70 mm (2.76 in.)	80 mm (3.15 in.)	80 mm (3.15 in.)	80 mm (3.15 in.)	90 mm (3.54 in.)	90 mm (3.54 in.)	100 mm (3.94 in.)
Pin Spread Minimum	Min. PS	280 mm (11.03 in.)	290 mm (11.42 in.)	345 mm (13.59 in.)	355 mm (13.98 in.)	376 mm (14.81 in.)	391 mm (15.40 in.)	430 mm (16.93 in.)	443 mm (17.44 in.)	458 mm (18.04 in.)	472 mm (18.58 in.)	500 mm (19.69 in.)
Pin Spread Maximum	Max. PS	317 mm (12.48 in.)	320 mm (12.59 in.)	415 mm (16.33 in.)	420 mm (16.53 in.)	472 mm (18.58 in.)	477 mm (18.77 in.)	520 mm (20.47 in.)	520 mm (20.47 in.)	525 mm (20.66 in.)	602 mm (23.70 in.)	607 mm (23.90 in.)
Coupler Vertical Offset	Vo	190 mm (7.48 in.)		224 mm (8.82 in.)		267 mm (10.51 in.)		272 mm (10.71 in.)	315 mm (12.40 in.)		338 mm (13.31 in.)	
Coupler Horizontal Offset	Ho	139 mm (5.47 in.)		224 mm (8.82 in.)		190 mm (7.48 in.)		217 mm (8.54 in.)	248 mm (9.76 in.)		263 mm (10.35 in.)	
Lift-Eye Rating		5000 kg (11,023 lb.)		13 000 kg (28,660 lb.)		13 000 kg (28,660 lb.)		13 000 kg (28,660 lb.)	20 000 kg (44,092 lb.)		25 000 kg (55,115 lb.)	

Contact your local dealer for more information.

[Back to Table of Contents](#)

# COUPLERS

EXCAVATORS (continued)

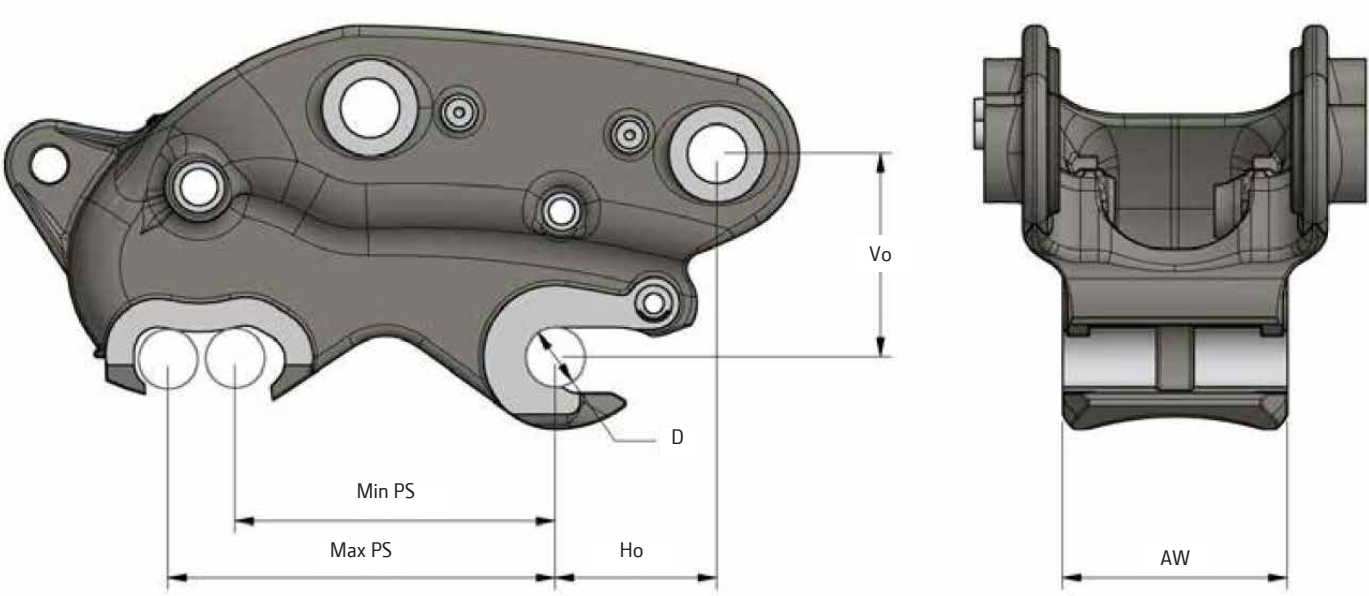

Artwork courtesy of Paladin®.

Contact your local dealer for more information.

[Back to Table of Contents](#)



# FORKS

BACKHOES | LOADERS

## FEATURES

### For 210L EP/210L Tractor Loaders and 310L EP/310L/310SL/310SL HL/410L Backhoes:

- Heavy-duty frame and fork design optimizes performance and visibility.
- Fork tines are manually adjustable.
- 48- and 60-inch ITA Class III tine lengths are available at 9,900-pounds-per-pair load rating.
- Fork-level guide mounted to fork frame provides a convenient, highly visible reference.

### For 444 P-Tier/524 P-Tier/544 G-Tier/544 P-Tier/624 P-Tier Loaders:

- Construction utility forks are compatible with John Deere standard loader couplers for comparable J-, K-, and L-Series models as well as competitive couplers with JRB 416 interface.
- Frame widths measure 60 and 96 inches.
- Construction utility forks are also compatible with Deere Hi-Vis loader couplers for comparable J-, K-, and L-Series models as well as competitive couplers meeting ISO 23727.
- Fork-tine lengths measure 48, 60, and 72 inches.
- Tines and shafts are heavy-duty rated.
- Compatibility and visibility are optimized for Deere utility loaders equipped with a Deere coupler.
- Tine adjustment is simple, fast, and integrated — no tools are needed.
- Tall fork frame provides material support.

### For 644 G-Tier/644 P-Tier/644 X-Tier/724 P-Tier Loaders:

- Construction utility forks are compatible with John Deere standard loader couplers for comparable J-, K-, and L-Series models as well as competitive couplers with JRB 418 interface.
- Frame widths measure 60 and 96 inches.
- Construction utility forks are also compatible with Deere Hi-Vis loader couplers for comparable J-, K-, and L-Series models as well as competitive couplers meeting ISO 23727.
- Fork-tine lengths measure 48, 60, and 72 inches.
- Tines and shafts are heavy-duty rated.
- Compatibility and visibility are optimized for Deere utility loaders equipped with a Deere coupler.
- Tine adjustment is simple, fast, and integrated — no tools are needed.
- Tall fork frame provides material support.

Contact your local dealer for more information.

[Back to Table of Contents](#)

# FORKS

BACKHOES | LOADERS (continued)



## FEATURES AND SPECIFICATIONS

### For 744 P-Tier and 824 P-Tier Loaders:

- Construction utility forks are compatible with John Deere standard loader couplers as well as competitive couplers with JRB 420 interface.
- Tines and shafts are heavy-duty rated.
- Fork-tine lengths measure 72 and 96 inches.
- Compatibility and visibility are optimized with Deere utility loaders equipped with a Deere coupler.
- Frame width measures 106 inches.
- Tall fork frame provides material support.
- Integrated attachment rollback stops within the frame.

Model	444 P-Tier	524 P-Tier	544 P-Tier	624 P-Tier	644 P-Tier	724 P-Tier	744 P-Tier	824 P-Tier
<b>Coupler Interface</b>								
Standard, JRB 416	•	•	•	•				
Standard, JRB 418					•	•		
Standard, JRB 420							•	•
Hi-Vis	•	•	•	•	•	•		
<b>Fork Frame Width</b>								
60-in. Construction	•	•	•	•				
96-in. Construction	•	•	•	•	•	•		
76-in. Floating (log)					•	•		
106-in. Construction					•	•	•	•
<b>Fork Tine Length</b>								
48 in.	•	•	•	•				
60 in.	•	•	•	•	•	•		
72 in.	•	•	•	•	•	•	•	•
96 in.							•	•
<i>See machine brochure for lift capacities.</i>								

Contact your local dealer for more information.

[Back to Table of Contents](#)



  
DKACEATCH (22-10)



**JOHN DEERE**