

PowerTech™

6068SFM85 Diesel Engine

Marine Propulsion Engine Specifications



Dimensions

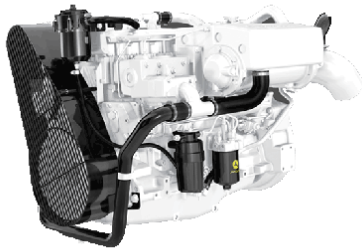

6068SFM85 shown

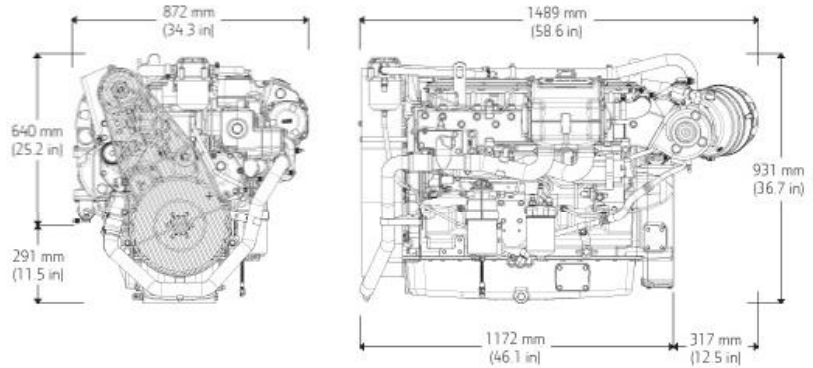

Dimensions shown in mm (in) may vary according to options selected. Contact your distributor for more information.

Emissions

EPA Commercial Marine Tier 3

IMO MARPOL Annex VI Tier II Compliant

General Data (Based on Standard Option Configuration)

Model	6068SFM85	Length maximum - mm (in)	1489 (58.6)
Number of cylinders	6	Height - mm (in)	931 (36.7)
Displacement - L (cu in)	6.8 (415)	Height, crankshaft centerline to top - mm (in)	640 (25.2)
Bore and Stroke-- mm (in)	106 x 127 (4.17 x 5.00)	Height, crankshaft centerline to bottom - mm (in)	291 (11.5)
Engine Type	In-line, 4- Cycle	Weight, dry - kg (lb)	763 (1682)
Aspiration	Air-to-sea water		

Classification Societies

ABS,BV,CCS,CRS,DNV-GL,LR

*SOLAS and other accessories available. Contact your distributor for details.

Engine Specifications

Performance ratings	Power kW (bhp)	Rated Speed (rpm)	Rated fuel consumption L/hr (gal/hr)
M1	186 (249)	2400	51.1 (13.5)
M2	209 (280)	2500	56.7 (15.0)
M3	239 (321)	2600	63.3 (16.7)
M4	265 (355)	2700	69.3 (18.3)
M5	298 (400)	2800	81.3 (21.5)

Metric hp = Brake hp x 1.01387

M rating	M1	M2	M3	M4	M5
Typical load factor	> 65%	< =65%	< =50%	< =40%	< =35%
Typical annual usage (hr)	Unrestricted	3,000-5,000 hr	2,000-4,000 hr	1,000-3,000 hr	300-1,000 hr
Typical full-power operation (hr)	Uninterrupted	16 of each 24 hr	4 of each 12 hr	1 of each 12 hr	0.5 of each 8 hr

Ratings are based on ISO 8655 standard power rating and the SAE J1 228 crankshaft power rating.

Flexibility of installation due to range of options.

See your John Deere Power Systems engine distributor or marine dealer for more detailed performance information.

Features and Benefits

High Torque and Low Rated RPM

- High torque provides excellent vessel control and maneuverability. Lower rated propulsion RPM reduces vibration and noise for improved crew comfort.

4-Valve Cylinder Head

- Excellent airflow through 4-valve cylinder head delivers greater low-speed torque and better transient response time.

High-pressure Common-rail (HPCR)

- The HPCR fuel system provides variable common-rail pressure, multiple injections, and higher injection pressures. It also controls fuel injection timing and provides precise control for the start, duration, and end of injection. Electronic transfer pump is self-priming for ease of maintenance. Provides high performance, excellent fuel economy, and low emissions.

Water-cooled Exhaust Manifold

- Integrated components eliminate external hoses and fittings that can leak or break. Wet exhaust manifold creates a cooler and quieter environment for passengers and crew.

Turbocharged With Air-to-Seawater Aftercooling

- Cooler turbocharger operation enables higher ratings and efficiencies for applications that require high power or speed.

Replaceable Cylinder Liners

- Replaceable wet-type cylinder liners are precision-machined and hardened for long life. Allows engine to be rebuilt to original specifications.

Electronic Engine Control Unit (ECU)

- Advanced fault code diagnostics and customizable engine protections ensure reliability and uptime. Provides highly customizable features and trim to integrate your vessel.

Heat Exchanger

- High-capacity heat exchanger provides reliable operation in adverse conditions.

Multiple Service Options

- Either-side oil fill/dipstick combinations and remote oil and fuel filter options are available for easier service access.