

5 0 - 6 0 - F O O T M A X I M U M R E A C H



JOHN DEERE

C

EXCAVATORS

200C LC / 230C LC / 270C LC / 330C LC



SUPER-LONG-FRONT

Specifications



Operating Weights	200C LC	230C LC	270C LC	330C LC
With full fuel tank; 175-lb. (79 kg) operator; and 32-in. (800 mm) triple semi-grouser shoes				
0.5-cu.-yd. (0.38 m ³), 30-in. (762 mm) wide, 835-lb. (379 kg) bucket; 24-ft. 3-in. (7.4 m) arm; 10,270-lb. (4658 kg) standard counterweight with optional 2,100-lb. (953 kg) counterweight; and 14-ft. 8-in. (4.46 m) undercarriage length with 7-ft. 10-in. (2.39 m) wide gauge	48,430 lb. (21 974 kg)			
0.5-cu.-yd. (0.38 m ³), 30-in. (762 mm) wide, 835-lb. (379 kg) bucket; 29-ft. 7-in. (9.0 m) arm; 11,265-lb. (5110 kg) standard counterweight with optional 3,400-lb. (1542 kg) counterweight; and 15-ft. 3-in. (4.64 m) undercarriage length with 8-ft. 6-in. (2.59 m) wide gauge		57,625 lb. (26 146 kg)		
0.5-cu.-yd. (0.38 m ³), 30-in. (762 mm) wide, 835-lb. (379 kg) bucket; 29-ft. 7-in. (9.0 m) arm; 13,468-lb. (6109 kg) standard counterweight with optional 2,250-lb. (1021 kg) counterweight; and 16-ft. 2-in. (4.94 m) undercarriage length with 8-ft. 6-in. (2.59 m) wide gauge			64,890 lb. (29 442 kg)	
1.44-cu.-yd. (1.1 m ³), 60-in. (1524 mm) wide, 1,500-lb. (680 kg) bucket; 28-ft. 8-in. (8.75 m) arm; 15,018-lb. (6812 kg) standard counterweight with optional 3,400-lb. (1542 kg) counterweight; and 16-ft. 2-in. (4.94 m) undercarriage length with 8-ft. 6-in. (2.59 m) wide gauge				75,577 lb. (34 291 kg)

200C LC / 230C LC Buckets

Type	standard	ditching
Width	30 in. (762 mm)	60 in. (1524 mm)
Capacity, SAE (heaped)	0.5 cu. yd. (0.38 m ³)	0.75 cu. yd. (0.57 m ³)*
Weight	800 lb. (363 kg)	890 lb. (404 kg)
Tip radius	44.7 in. (1135 mm)	37.3 in. (945 mm)
Teeth	six TF23D	none
Drainage holes	no	yes

*Note: 0.75-cu. yd. bucket restricted to materials below 1,854 lb./cu. yd.

270C LC Buckets

Type	standard	ditching
Width	30 in. (762 mm)	60 in. (1524 mm)
Capacity, SAE (heaped)	0.5 cu. yd. (0.38 m ³)	0.9 cu. yd. (0.69 m ³)
Weight	800 lb. (363 kg)	1,020 lb. (463 kg)
Tip radius	44.7 in. (1135 mm)	38.6 in. (981 mm)
Teeth	six TF23D	none
Drainage holes	no	yes

*Note: 0.9-cu. yd. bucket restricted to materials below 1,854 lb./cu. yd.

330C LC Buckets

Type	standard	ditching
Width	36 in. (914 mm)	60 in. (1524 mm)
Capacity, SAE (heaped)	0.65 cu. yd. (0.5 m ³)	1.44 cu. yd. (1.1 m ³)
Weight	967 lb. (439 kg)	1,500 lb. (680 kg)
Tip radius	46.9 in. (1190 mm)	46.5 in. (1181 mm)
Teeth	seven TF23D	none
Drainage holes	no	yes

*Note: 1.44-cu. yd. bucket restricted to materials below 1,854 lb./cu. yd.

Operating Information

	200C LC	230C LC	270C LC	330C LC
Arm length	24 ft. 3 in. (7.4 m)	29 ft. 7 in. (9.0 m)	29 ft. 7 in. (9.0 m)	28 ft. 8 in. (8.8 m)
Arm force with 60-in. (1525 mm) bucket.....	10,700 lb. (4840 kg)	10,800 lb. (4900 kg)	10,800 lb. (4900 kg)	16,000 lb. (7280 kg)
Bucket digging force with 60-in. (1525 mm) bucket.....	18,800 lb. (8545 kg)	18,800 lb. (8525 kg)	18,800 lb. (8525 kg)	19,500 lb. (8840 kg)
Bucket cutting edge tip radius.....	37 in. (940 mm)	37 in. (940 mm)	37 in. (940 mm)	46 in. (1180 mm)
Lifting capacity over front or rear @ ground level				
20-ft. (6.1 m) reach.....	10,640 lb. (4827 kg)	11,070 lb. (5022 kg)	14,200 lb. (6440 kg)	19,670 lb. (8925 kg)
A Maximum reach	50 ft. 4 in. (15 330 mm)	59 ft. 11 in. (18 250 mm)	59 ft. 11 in. (18 250 mm)	59 ft. 11 in. (18 250 mm)
A' Maximum reach @ ground level.....	50 ft. 0 in. (15 230 mm)	59 ft. 7 in. (18 160 mm)	59 ft. 7 in. (18 160 mm)	59 ft. 7 in. (18 150 mm)
B Maximum digging depth.....	37 ft. 11 in. (11 550 mm)	45 ft. 8 in. (13 920 mm)	46 ft. 5 in. (14 150 mm)	45 ft. 11 in. (14 000 mm)
C Maximum cutting height.....	44 ft. 7 in. (13 600 mm)	51 ft. 10 in. (15 810 mm)	48 ft. 9 in. (14 870 mm)	47 ft. 8 in. (14 530 mm)
D Maximum dumping height.....	36 ft. 11 in. (11 250 mm)	44 ft. (13 410 mm)	41 ft. 10 in. (12 760 mm)	38 ft. 11 in. (11 870 mm)

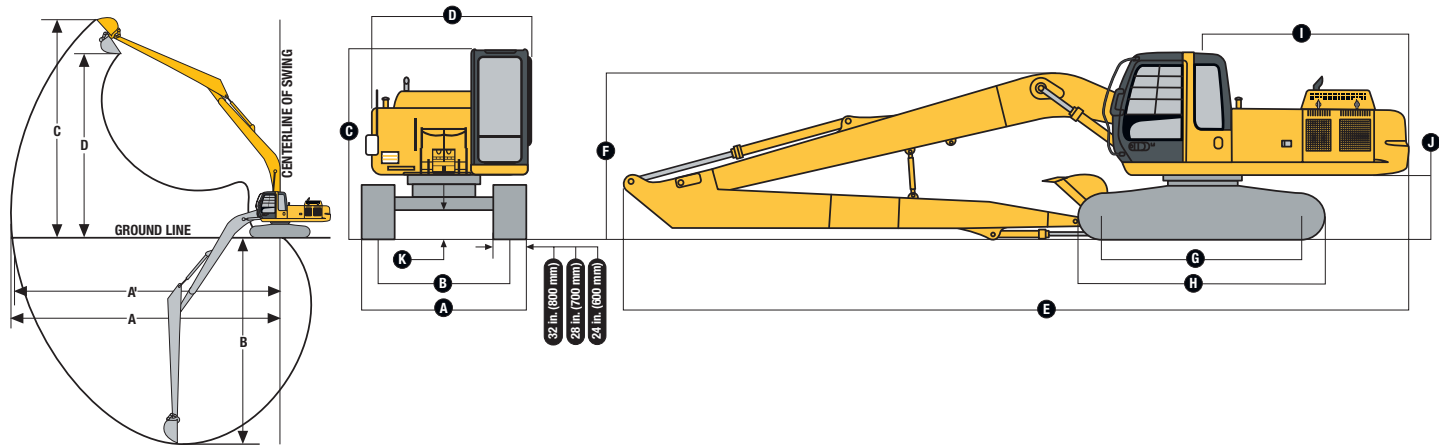

Dimensions

A With 24-in. (600 mm) semi-grouser shoes	9 ft. 10 in. (2.99 m)	10 ft. 6 in. (3.19 m)	10 ft. 6 in. (3.19 m)	10 ft. 6 in. (3.19 m)
With 28-in. (700 mm) semi-grouser shoes	10 ft. 2 in. (3.09 m)	10 ft. 10 in. (3.29 m)	N/A	N/A
With 32-in. (800 mm) semi-grouser shoes	10 ft. 6 in. (3.19 m)	11 ft. 1 in. (3.39 m)	11 ft. 1 in. (3.39 m)	11 ft. 1 in. (3.39 m)
B Gauge width.....	7 ft. 10 in. (2.39 m)	8 ft. 6 in. (2.59 m)	8 ft. 6 in. (2.59 m)	8 ft. 6 in. (2.59 m)
C Cab height.....	9 ft. 8 in. (2.95 m)	9 ft. 11 in. (3.02 m)	10 ft. 2 in. (3.11 m)	10 ft. 4 in. (3.14 m)
D Upperstructure width.....	8 ft. 11 in. (2.71 m)	9 ft. 6 in. (2.89 m)	9 ft. 6 in. (2.89 m)	9 ft. 10 in. (3.00 m)
E Overall length.....	39 ft. 3 in. (12.08 m)	45 ft. 6 in. (13.87 m)	45 ft. 4 in. (13.81 m)	47 ft. 7 in. (14.50 m)
F Transport height.....	9 ft. 6 in. (3.13 m)	10 ft. 8 in. (3.25 m)	10 ft. 8 in. (3.25 m)	10 ft. 10 in. (3.31 m)
G Distance between idler/sprocket centerline	12 ft. 0 in. (3.66 m)	12 ft. 7 in. (3.84 m)	13 ft. 3 in. (4.05 m)	13 ft. 3 in. (4.05 m)
H Undercarriage length.....	14 ft. 8 in. (4.46 m)	15 ft. 3 in. (4.64 m)	16 ft. 2 in. (4.94 m)	16 ft. 2 in. (4.94 m)
I Rear-end swing radius	9 ft. 0 in. (2.75 m)	9 ft. 8 in. (2.94 m)	9 ft. 8 in. (2.94 m)	10 ft. 11 in. (3.32 m)
J Counterweight clearance.....	3 ft. 5 in. (1030 mm)	3 ft. 7 in. (1090 mm)	3 ft. 10 in. (1180 mm)	3 ft. 10 in. (1160 mm)
K Ground clearance	1 ft. 6 in. (450 mm)	1 ft. 6 in. (460 mm)	1 ft. 8 in. (510 mm)	1 ft. 8 in. (510 mm)

200C LC Lift Capacities

Boldface italic type indicates hydraulic-limited capacities; lightface type indicates stability-limited capacities, in lb. (kg). Ratings at bucket lift hook, machine equipped with 0.5-cu. yd. (0.38 m³), 30-in. (762 mm) wide, 835-lb. (379 kg) bucket; and situated on firm, uniform supporting surface. Total load includes weight of cables, hook, etc. Figures do not exceed 87 percent of hydraulic capacities or 75 percent of weight needed to tip machine. Lift capacities are with power boost and are based on SAE standard J1097.

Load Point Height	10 ft. (3.05 m)		20 ft. (6.10 m)		30 ft. (9.14 m)		40 ft. (12.19 m)	
	Over Front	Over Side	Over Front	Over Side	Over Front	Over Side	Over Front	Over Side
<i>With 24-ft. 3-in. (7.4 m) arm and 32-in. (800 mm) shoes</i>								
25 ft. (7.64 m)							3,010 (1366)	3,010 (1366)
20 ft. (6.10 m)							3,690 (1674)	3,630 (1647)
15 ft. (4.57 m)							3,920 (1779)	3,510 (1593)
10 ft. (3.05 m)					4,850 (2201)	4,850 (2201)	4,260 (1933)	3,350 (1520)
5 ft. (1.52 m)	4,260 (1933)	4,260 (1933)	8,540 (3875)	8,540 (3875)	5,710 (2591)	5,410 (2455)	4,640 (2105)	3,180 (1443)
Ground Line	3,050 (1384)	3,050 (1384)	10,570 (4796)	9,160 (4156)	6,560 (2976)	5,020 (2278)	5,030 (2282)	3,010 (1366)
-5 ft. (-1.52 m)	4,480 (2033)	4,480 (2033)	12,050 (5467)	8,480 (3848)	7,300 (3312)	4,700 (2132)	5,000 (2269)	2,870 (1302)
-10 ft. (-3.05 m)	6,440 (2922)	6,440 (2922)	12,920 (5862)	8,100 (3675)	7,610 (3453)	4,470 (2028)	4,900 (2223)	2,770 (1257)
-15 ft. (-4.57 m)	8,760 (3975)	8,760 (3975)	13,260 (6016)	7,960 (3612)	7,480 (3394)	4,350 (1974)	4,860 (2205)	2,730 (1239)
-20 ft. (-6.10 m)	11,490 (5213)	11,490 (5213)	13,100 (5944)	7,990 (3625)	7,470 (3389)	4,330 (1965)	3,700 (1679)	2,790 (1266)
-25 ft. (-7.64 m)	14,900 (6760)	14,900 (6760)	12,380 (5617)	8,170 (3707)	7,570 (3435)	4,430 (2010)		
-30 ft. (-9.14 m)	19,370 (8789)	19,370 (8789)	10,920 (4955)	8,520 (3866)	6,590 (2990)	4,700 (2132)		

200C LC / 230C LC / 270C LC / 330C LC SUPER-LONG-FRONT EXCAVATORS SPECIFICATIONS (continued)

230C LC Lift Capacities

Boldface italic type indicates hydraulic-limited capacities; lightface type indicates stability-limited capacities, in lb. (kg). Ratings at bucket lift hook, machine equipped with 0.5-cu. yd. (0.38 m³), 30-in. (762 mm) wide, 835-lb. (379 kg) bucket; and situated on firm, uniform supporting surface. Total load includes weight of cables, hook, etc. Figures do not exceed 87 percent of hydraulic capacities or 75 percent of weight needed to tip machine. Lift capacities are with power boost and are based on SAE standard J1097.

Load Point Height	10 ft. (3.05 m)		20 ft. (6.10 m)		30 ft. (9.14 m)		40 ft. (12.19 m)	
	Over Front	Over Side	Over Front	Over Side	Over Front	Over Side	Over Front	Over Side
<i>With 29-ft. 7-in. (9.0 m) arm and 32-in. (800 mm) shoes</i>								
20 ft. (6.10 m)							3,030 (6778)	3,030 (6778)
15 ft. (4.57 m)							3,400 (1543)	3,400 (1543)
10 ft. (3.05 m)					4,650 (2110)	4,650 (2110)	3,850 (1747)	3,850 (1747)
5 ft. (1.52 m)			8,910 (4043)	8,910 (4043)	5,620 (2550)	5,620 (2550)	4,330 (1965)	4,330 (1965)
Ground Line	2,060 (935)	2,060 (935)	11,070 (5023)	11,070 (5023)	6,570 (2981)	6,570 (2981)	4,820 (2187)	4,080 (1851)
-5 ft. (-1.52 m)	3,220 (1461)	3,220 (1461)	12,680 (5753)	10,620 (4819)	7,410 (3362)	6,050 (2745)	5,280 (2396)	3,800 (1724)
-10 ft. (-3.05 m)	4,720 (2142)	4,720 (2142)	13,720 (6225)	9,990 (4533)	8,090 (3671)	5,640 (2559)	5,680 (2577)	3,570 (1620)
-15 ft. (-4.57 m)	6,410 (2908)	6,410 (2908)	14,290 (6484)	9,690 (4397)	8,590 (3897)	5,380 (2441)	5,950 (2700)	3,410 (1547)
-20 ft. (-6.10 m)	8,300 (3766)	8,300 (3766)	14,450 (6556)	9,630 (4369)	8,870 (4025)	5,250 (2382)	5,870 (2663)	3,330 (1511)
-25 ft. (-7.64 m)	10,450 (4741)	10,450 (4741)	14,250 (6466)	9,750 (4424)	8,910 (4043)	5,250 (2382)	5,870 (2663)	3,340 (1515)
-30 ft. (-9.14 m)	12,980 (5889)	12,980 (5889)	13,640 (6189)	10,010 (4542)	8,670 (3934)	5,360 (2432)	5,950 (2700)	3,450 (1565)
-35 ft. (-10.67 m)	16,120 (7314)	16,120 (7314)	12,510 (5676)	10,440 (4737)	8,030 (3643)	5,600 (2541)	5,170 (2346)	3,720 (1688)
-40 ft. (-12.19 m)	10,650 (4832)	10,650 (4832)	6,700 (3040)	6,040 (2740)				

270C LC Lift Capacities

Boldface italic type indicates hydraulic-limited capacities; lightface type indicates stability-limited capacities, in lb. (kg). Ratings at bucket lift hook, machine equipped with 0.5-cu. yd. (0.38 m³), 30-in. (762 mm) wide, 835-lb. (379 kg) bucket; and situated on firm, uniform supporting surface. Total load includes weight of cables, hook, etc. Figures do not exceed 87 percent of hydraulic capacities or 75 percent of weight needed to tip machine. Lift capacities are with power boost and are based on SAE standard J1097.

Load Point Height	10 ft. (3.05 m)		20 ft. (6.10 m)		30 ft. (9.14 m)		40 ft. (12.19 m)	
	Over Front	Over Side	Over Front	Over Side	Over Front	Over Side	Over Front	Over Side
<i>With 29-ft. 7-in. (9.0 m) arm and 32-in. (800 mm) shoes</i>								
15 ft. (4.57 m)							4,560 (2069)	4,560 (2069)
10 ft. (3.05 m)							5,130 (2328)	5,130 (2328)
5 ft. (1.52 m)			11,460 (5200)	11,460 (5200)	7,350 (3335)	7,350 (3335)	5,760 (2613)	5,160 (2341)
Ground Line	2,060 (935)	2,060 (935)	14,200 (6443)	13,480 (6116)	8,560 (3884)	7,660 (3475)	6,380 (2895)	4,830 (2191)
-5 ft. (-1.52 m)	3,250 (1475)	3,250 (1475)	15,980 (7250)	12,390 (5622)	9,620 (4365)	7,110 (3226)	6,970 (3162)	4,550 (2064)
-10 ft. (-3.05 m)	4,770 (2164)	4,770 (2164)	14,500 (6579)	11,780 (5345)	10,470 (4750)	6,700 (3040)	7,470 (3389)	4,320 (1960)
-15 ft. (-4.57 m)	6,470 (2936)	6,470 (2936)	15,270 (6928)	11,500 (5218)	11,080 (5027)	6,450 (2926)	7,570 (3435)	4,170 (1892)
-20 ft. (-6.10 m)	8,370 (3798)	8,370 (3798)	17,270 (7836)	11,450 (5195)	11,370 (5159)	6,330 (2872)	7,490 (3398)	4,090 (1856)
-25 ft. (-7.64 m)	10,540 (4782)	10,540 (4782)	18,040 (8185)	11,570 (5250)	11,370 (5159)	6,330 (2872)	7,500 (3403)	4,100 (1860)
-30 ft. (-9.14 m)	13,100 (5944)	13,100 (5944)	17,250 (7827)	11,850 (5377)	11,120 (5045)	6,450 (2926)	7,620 (3457)	4,220 (1915)
-35 ft. (-10.67 m)	16,270 (7382)	16,270 (7382)	15,840 (7187)	12,290 (5577)	10,300 (4673)	6,700 (3040)		
-40 ft. (-12.19 m)			13,500 (6125)	12,930 (5867)	8,600 (3902)	7,150 (3244)		

330C LC Lift Capacities

Boldface italic type indicates hydraulic-limited capacities; lightface type indicates stability-limited capacities, in lb. (kg). Ratings at bucket lift hook, machine equipped with 1.44-cu. yd. (1.1 m³), 60-in. (1524 mm) wide, 1,500-lb. (680 kg) bucket; and situated on firm, uniform supporting surface. Total load includes weight of cables, hook, etc. Figures do not exceed 87 percent of hydraulic capacities or 75 percent of weight needed to tip machine. Lift capacities are with power boost and are based on SAE standard J1097.

Load Point Height	10 ft. (3.05 m)		20 ft. (6.10 m)		30 ft. (9.14 m)		40 ft. (12.19 m)	
	Over Front	Over Side	Over Front	Over Side	Over Front	Over Side	Over Front	Over Side
<i>With 28-ft. 8-in. (8.75 m) arm and 32-in. (800 mm) shoes</i>								
15 ft. (4.57 m)							7,430 (3371)	6,910 (3135)
10 ft. (3.05 m)			12,200 (5535)	12,200 (5535)	10,310 (4678)	10,310 (4678)	8,160 (3702)	6,540 (2967)
5 ft. (1.52 m)			19,230 (8725)	17,860 (8103)	11,860 (5381)	9,940 (4510)	8,910 (4043)	6,160 (2795)
Ground Line	2,050 (930)	2,050 (930)	19,670 (8925)	16,200 (7350)	13,250 (6012)	9,220 (4183)	9,620 (4365)	5,800 (2632)
-5 ft. (-1.52 m)	4,360 (1978)	4,360 (1978)	18,740 (8503)	15,210 (6901)	14,350 (6511)	8,650 (3925)	9,500 (4310)	5,500 (2495)
-10 ft. (-3.05 m)	6,870 (3117)	6,870 (3117)	18,430 (8362)	14,710 (6674)	14,200 (6443)	8,250 (3743)	9,250 (4197)	5,270 (2391)
-15 ft. (-4.57 m)	9,620 (4365)	9,620 (4365)	18,320 (8312)	14,520 (6588)	13,940 (6325)	8,010 (3634)	9,090 (4124)	5,110 (2319)
-20 ft. (-6.10 m)	12,300 (5581)	12,300 (5581)	18,520 (8403)	14,550 (6602)	13,840 (6280)	7,910 (3589)	9,020 (4093)	5,050 (2291)
-25 ft. (-7.64 m)	14,270 (6475)	14,270 (6475)	18,900 (8575)	14,750 (6692)	13,880 (6298)	7,950 (3607)	9,050 (4106)	5,080 (2305)
-30 ft. (-9.14 m)	16,050 (7282)	16,050 (7282)	19,350 (8779)	15,100 (6851)	13,820 (6270)	8,110 (3680)	9,210 (4179)	5,220 (2368)
-35 ft. (-10.67 m)	17,610 (7990)	17,610 (7990)	17,930 (8135)	15,620 (7087)	11,990 (5440)	8,420 (3820)		
-40 ft. (-12.19 m)			13,700 (6216)	13,700 (6216)	8,780 (3984)	8,780 (3984)		



JOHN DEERE

DKAXCLCLF Litho in U.S.A. (05-02)

Net engine power is with standard equipment including air cleaner, exhaust system, alternator, and cooling fan, at standard conditions per SAE J1349 and DIN 6270B, using No. 2-D fuel at 35 API gravity. No derating is required up to 10,000-ft. (3050 m) altitude. Gross power is without cooling fan.

Specifications and design subject to change without notice. Wherever applicable, specifications are in accordance with SAE standards. Except where otherwise noted, these specifications are based on units with full fuel tanks and 175-lb. (79 kg) operators; a 200C LC unit with 30-in. (762 mm) bucket, 32-in. (800 mm) track shoes, and 10,270-lb. (4658 kg) counterweight; a 230C LC unit with 30-in. (762 mm) bucket, 32-in. (800 mm) track shoes, and 11,265-lb. (5110 kg) counterweight; a 270C LC unit with 30-in. (762 mm) bucket, 32-in. (800 mm) track shoes, and 13,468-lb. (6109 kg) counterweight; and a 330C LC unit with 60-in. (1524 mm) bucket, 32-in. (800 mm) track shoes, and 15,018-lb. (6812 kg) counterweight.

